



4-Cycle Snow King Operator's Manual

Horizontal Crankshaft • Air-Cooled

LH195SA/LH195SP
LH318SA/LH358SA
OH195SA/OH195SP
OH318SA/OH358SA

ENGINE
MODEL: _____

SPEC: _____

D.O.M.: _____

Visit our web site at www.TecumsehPower.com

- ◆ Register Your Tecumseh Engine
- ◆ Maintenance Tips
- ◆ Parts Look-Up System
- ◆ Great Tecumseh Apparel
- ◆ Nearest Authorized Tecumseh Servicing Dealer Location

LOG ON!

181-1275-14
(English) 01/01/07

Table of Contents

Safety Definitions	ii
I. General Safety Precautions	1
II. How to Get Service	3
III. Oil and Fuel Specifications.....	4
IV. Before Starting Your Engine	4
V. Starting Your Engine	9
VI. Stopping Your Engine and Short-Term Storage	15
VII. Maintenance	17
VIII. Transporting Your Engine.....	22
IX. Storing Your Engine	24
X. Preventing Forest, Brush and Grass Fires.....	26
XI. Maintenance Intervals.....	26
California & US EPA Emission Control Warranty Statement.....	28
Emission Control System Warranty	29
XII. Warranty Information.....	30

IMPORTANT NOTICE!

Safety Definitions

Statements in this manual preceded by the following words and graphics are of special significance:

WARNING

Or

WARNING

WARNING indicates a potentially hazardous situation which if NOT avoided, could result in death or serious injury.

CAUTION

Indicates a potential situation which if not avoided, could result in equipment or property damage.

NOTE

Refers to important information and is placed in italic type.

It is recommended that you take special notice of all items discussed on the next two pages and wear the appropriate safety equipment.

Before operating this engine *it is your responsibility* to read this Operator's Manual. Follow these basic rules for your personal safety:

- Keep this manual handy at all times for future reference.
- Read it carefully and familiarize yourself with operating, maintenance, components and safety instructions.

Notice Regarding Emissions

NOTE

Engines which are certified to comply with California and U.S. EPA emission regulations for SORE (Small Off Road Equipment), are certified to operate on regular unleaded gasoline, and may include the following emission control systems: (EM) Engine Modification and (TWC) Three-way Catalyst (if so equipped).

Tecumseh Contact Information

For engine adjustments, repairs or warranty service NOT covered in this manual, consult your local Authorized Tecumseh Servicing Dealer, call 1-800-558-5402, or go to www.TecumsehPower.com for additional information.

©Copyright 2006

Tecumseh Power Company

All Rights Reserved

I. General Safety Precautions

⚠ WARNING

Read equipment manufacturer's manual and this material thoroughly before using this engine. Failure to do so can result in serious injury or death. Consult your local Authorized Tecumseh Servicing Dealer, call 1-800-558-5402, or go to www.TecumsehPower.com for additional information.

A. Avoid Carbon Monoxide Poisoning

All engine exhaust contains carbon monoxide, a deadly gas. Breathing carbon monoxide can cause headaches, dizziness, drowsiness, nausea, confusion and eventually death.

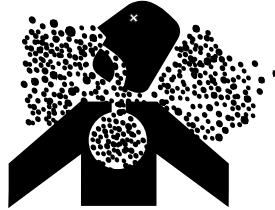

Carbon monoxide is a colorless, odorless, tasteless gas which may be present even if you DO NOT see or smell any engine exhaust. Deadly levels of carbon monoxide can collect rapidly and you can quickly be overcome and unable to save yourself. Also, deadly levels of carbon monoxide can linger for hours or days in enclosed or poorly-ventilated areas. If you experience any symptoms of carbon monoxide poisoning, leave the area immediately, get fresh air, and SEEK MEDICAL TREATMENT.

To prevent serious injury or death from carbon monoxide:

- NEVER run engine indoors. Even if you try to ventilate engine exhaust with fans or open windows and doors, carbon monoxide can rapidly reach dangerous levels.
- NEVER run engine in poorly-ventilated or partially enclosed areas such as barns, garages, basements, carports, under dwellings, or in pits.
- NEVER run engine outdoors where engine exhaust can be drawn into a building through openings such as windows and doors.

B. Avoid Gasoline Fires

Gasoline (fuel) vapors are highly flammable and can explode. Fuel vapors can spread and be ignited by a spark or flame many feet away from engine. To prevent injury or death from fuel fires, follow these instructions:



- NEVER store engine with fuel in fuel tank inside a building with potential sources of ignition such as hot water and space heaters, clothes dryers, electric motors, etc.
- NEVER remove fuel fill cap or add fuel when engine is running.
- NEVER start or operate the engine with the fuel fill cap removed.
- Allow engine to cool before refueling.

- NEVER fill fuel tank indoors. Fill fuel tank outdoors in a well-ventilated area.
- DO NOT smoke while refueling tank.
- Use only an approved red GASOLINE container to store and dispense fuel. Tecumseh recommends purchasing gasoline in containers with a capacity of 2.5 gallons or less. Small containers are easier to handle and help eliminate spillage during refueling.
- DO NOT pour fuel from engine or siphon fuel by mouth. To empty the fuel tank, see "I. Draining Fuel" instructions on page 24.

C. Adult Supervision of Operation, Refueling and Maintenance

The manufacturer of the equipment may provide information about who is allowed to use this engine (see equipment manufacturer's manual). NOT everyone who is allowed to use this engine is capable of safely and responsibly operating, maintaining and/or fueling it. Tecumseh recommends the following:

- An adult should fuel this engine. NEVER allow children to refuel this engine. See "E. Filling Fuel Tank" instructions on page 8.
- An adult should perform maintenance on this engine. See "VII. Maintenance" instructions on page 17. Only allow children to perform maintenance if an adult has determined they are experienced and capable of such operation.
- An adult should start the engine. See "G. Avoid Accidental Starts" instructions on page 2. Only allow children to start the engine if an adult has determined they are experienced and capable of such operation.
- To avoid unsupervised operation of the engine, especially by children, NEVER leave it unattended when it is running.
- Remove ignition key, if equipped.

D. Stay Away from Rotating Parts

NEVER operate the engine with an unguarded flywheel. See Figure 1 on page 2.

The equipment manufacturer may attach a sprocket and chain or pulley and belt to the engine shaft. If these parts are NOT properly guarded, or if you are NOT sure whether they are properly guarded, DO NOT use your engine; contact the equipment manufacturer. Hands, feet, hair, jewelry, clothing, etc. can become entangled in rotating parts, leading to serious injury or death. To avoid serious injury or death, be sure the flywheel guard is in place. See Figure 1 on page 2.

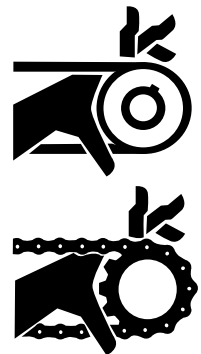

E. DO NOT Modify Engine

To avoid serious injury or death, DO NOT modify engine in any way. Tampering with the governor setting can lead to a runaway engine and cause it to operate at unsafe speeds. NEVER tamper with factory setting of engine governor.

⚠ WARNING

Use of this engine on fun-carts, go-karts, or mini-bikes can result in serious injury or death. Tecumseh manufactures the Power Sport line of engines for use in such applications. Consult your local Authorized Tecumseh Servicing Dealer, call 1-800-558-5402, or go to www.TecumsehPower.com for additional information.

F. Avoid Burns and Fire from Hot Surfaces

The muffler and other engine parts become extremely hot during operation and remain hot after the engine has stopped.



- To avoid severe burns on contact, STAY AWAY from hot areas of engine. DO NOT operate the engine without the muffler guard in place, if equipped. Tecumseh Power Company offers a muffler guard for all 4-Cycle Snow King Engines. Consult your local Authorized Tecumseh Servicing Dealer or call 1-800-558-5402 for additional information. See Figure 2.
- To reduce the risk of fire keep all materials that can burn, including grass and leaves, away from muffler and rest of engine. DO NOT operate, idle or park engine powered equipment in long dry grass or other dry ground cover.

G. Avoid Accidental Starts

To prevent accidental starting when working on equipment always:

- Carefully disconnect spark plug wire and keep it away from spark plug. See Figures 3 and 4.
 - Keep the disconnected spark plug wire securely away from metal parts where arcing could occur.
 - Carefully attach the spark plug wire to the grounding post, if provided.
- Disconnect battery at negative terminal first, if engine is equipped with a D.C. electric starter.
- Turn all engine switches to “OFF” position.
- Remove ignition key, if provided.

H. Use Hearing Protection

Engine noise may cause hearing damage. Always wear hearing protection when operating an engine.

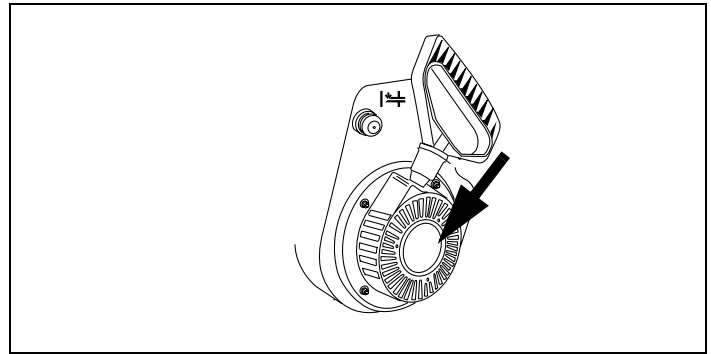

Figure 1. Typical Flywheel Guard Location

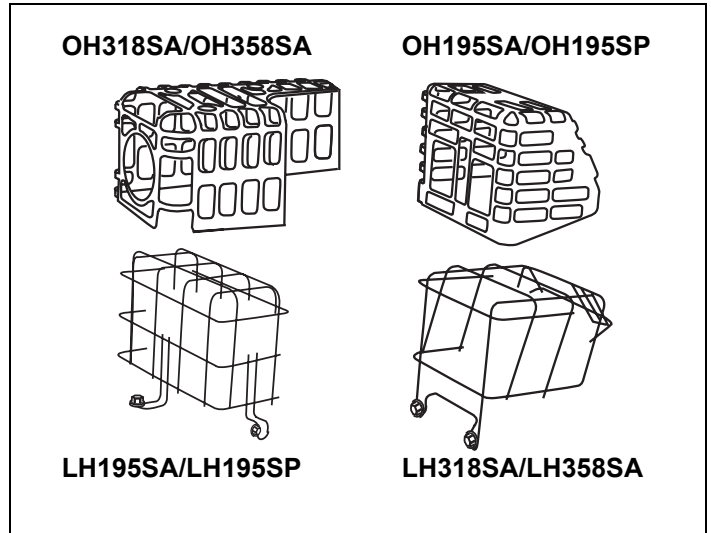

Figure 2. Muffler Guards Available

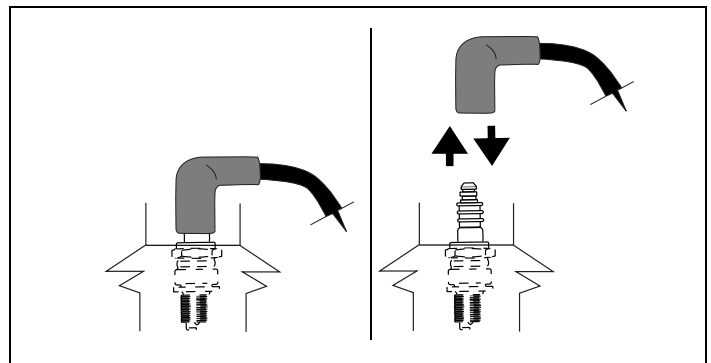

Figure 3. Disconnecting/Connecting Spark Plug

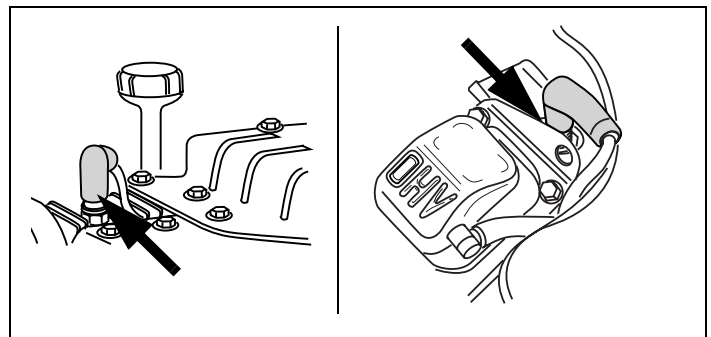

Figure 4. Typical Spark Plug Connection

II. How to Get Service

For engine adjustments, repairs or warranty service NOT covered in this manual, consult your local Authorized Tecumseh Servicing Dealer, call 1-800-558-5402, or go to www.TecumsehPower.com for additional information.

Visit our web site at www.TecumsehPower.com

- ◆ Register Your Tecumseh Engine
- ◆ Maintenance Tips
- ◆ Parts Look-Up System
- ◆ Great Tecumseh Apparel
- ◆ Nearest Authorized Tecumseh Servicing Dealer Location

LOG ON!

A. Engine Identification Decal

A sample engine identification decal is located in the next column and indicates the engine's model number, specification and date of manufacture (D.O.M.). See Figure 5.

NOTES

Please look at the decal on your engine.

Fill in the engine information in the spaces provided for future reference.

The engine identification decal also includes engine life specifications for the emissions-related useful life period of your engine. This period relates to the emission compliance life as certified by EPA and/or CARB.

- LH195SA/LH195SP and OH195SA/OH195SP models are designated as "C" 125 hours.
- LH318SA/LH358SA and OH318SA/OH358SA models are designated as "C" 250 hours.

B. Tecumseh Technician's Handbooks

If you have a general understanding of internal combustion engines and wish to repair and service your engine and/or engine emission control systems yourself, a Technician's Handbook is available from your Authorized Tecumseh Servicing Dealer. See Figure 6. This handbook covers repairs and adjustments NOT covered within this Operator's Manual, and it is intended for individuals who have had adequate training, experience and who practice proper tool usage. Service procedures should be clearly understood and practiced when servicing Tecumseh Engines.

- Order as part no. 695244A for OH195SA/OH195SP and OH318SA/OH358SA models.
- Order as part no. 692509 for LH195SA/LH195SP and LH318SA/LH358SA models.

Tecumseh manufactures and is responsible only for the engine used on this power equipment. If repair or service is needed for anything other than the engine, contact the service source recommended by the equipment manufacturer.

⚠ WARNING 2083

To avoid injury or death, read the engine operator's manual and the equipment owner's manual. Call 1(800)558-5402 for engine owner's manual.

--- IMPORTANT ENGINE INFORMATION ---

TECUMSEH POWER COMPANY

THIS ENGINE MEETS 1995-2005 CALIF & US EPA PHI APPLICABLE EMISSION REGULATIONS FOR SI SORE ENGINES EM

FUEL: REGULAR UNLEADED	OIL: SAE 30
MODEL: LV195EA	WARRANTY: (D)
SPEC: 361540D	DOM: 04015AA0001
ENGINE FAMILY: 4TPXS.1951BB	DISP: 195 cc

ENGINE MODEL: _____

SPEC: _____

D.O.M.: _____

Figure 5. Engine Identification Decal

TECUMSEH

TECHNICIAN'S HANDBOOK

OVERHEAD VALVE
4 - CYCLE
ENGINES

TECUMSEH

TECHNICIAN'S HANDBOOK

3 TO 11 HP
4 - CYCLE
L - HEAD
ENGINES

Figure 6. Technician's Handbooks

III. Oil and Fuel Specifications

A. Oil

To operate engine you need to use a clean, high quality, detergent oil. For recommended engine oil, see Table 1. In addition, you need to be sure the oil sump contains the correct amount of oil to operate properly. For recommended oil sump capacity, see Table 2.

NOTES

Be sure original container is marked A.P.I. Service "SL/SJ".

Using multigrade oil above 32°F (0°C) will increase oil consumption. SAE 10W40 is NOT recommended.

Tecumseh special-formulated oils are available at your Authorized Tecumseh Servicing Dealer.

B. Fuel

Use unleaded regular, unleaded premium or reformulated automotive fuel only. You may use gasoline containing the components identified in Table 3.

- DO NOT use leaded fuel.
- Fuel must be fresh and clean. NEVER use fuel left over from last season or stored for long periods.
- NEVER mix oil with fuel.
- DO NOT use fuel containing Methanol (Wood Alcohol).

CAUTION

The use of alternative fuels such as E85 or E20 are not recommended for use in Tecumseh engines. Alternative fuels with high alcohol content can cause hard starting, poor engine performance, and may cause internal engine damage.

NOTE

Damage and/or performance problems that will occur from use of fuels, other than those listed in the Operator's Manuals will not be considered warranty.

IV. Before Starting Your Engine

A. Checking Oil Level

To avoid engine damage, it is important to:

- Check oil level before each use and every 5 operating hours when engine is warm. Check oil level more frequently during engine break-in.
- Keep oil level between "FULL" and "ADD" marks on oil fill cap/dipstick or to point of overflow on engines with an oil fill cap/plug. See Figure 7.
- Be sure oil fill cap/dipstick or oil fill cap/plug is tightened securely.

NOTES

DO NOT overfill oil filler. Doing so may result in oil carry-over to the equipment and cause malfunction or damage.

DO NOT allow oil level to fall below the "ADD" mark on oil fill cap/dipstick. Doing so may result in equipment malfunction or damage.

Contact your Authorized Tecumseh Servicing Dealer for Tecumseh Oil.

Some engines are equipped with an oil fill cap/dipstick or oil fill cap/plug (see equipment manufacturer's instructions). To change the oil on your engine, see "B. Changing Oil" instructions on page 17.

Table 1. Recommended Oil

Tecumseh Recommended Oil Usage										
							Straight Grade Tecumseh Part No. 730225A or SAE 30			
					Multi Grade Tecumseh Part No. 730226A or SAE 5W30 or SAE 10					
						Synthetic Tecumseh Part No. 730263 or SAE 0W30				
-30°F	-20°F	0°F	20°F	32°F	40°F	60°F	80°F	100°F		
-30°C	-20°C	-10°C	0°C		10°C	20°C	30°C	40°C		

Table 2. Oil Sump Capacity

Oil Sump Capacity			Engine
Ounces	U.S. Pints	Liters	Model Number
21	1-1/4	.62	LH195SA/LH195SP OH195SA/OH195SP
26	1-5/8	.77	LH318SA/LH358SA OH318SA
28	1-3/4	.83	OH358SA

Table 3. Recommended Fuel

Fuel Component	Percentage
Ethanol	10%
Grain Alcohol ("Gasohol")	10%
MTBE (Methyl Tertiary Butyl Ether)	15%
ETBE (Ethyl Tertiary Butyl Ether)	15%

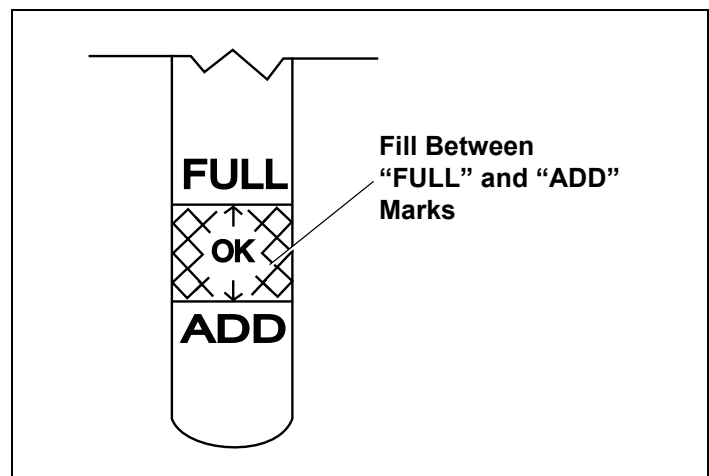

Figure 7. Engine Oil Level

B. Filling Oil Sump

I. Oil Fill Cap/Dipstick

If your engine has an oil fill cap/dipstick go to step 1. If your engine does NOT have an oil fill cap/dipstick, see "II. Oil Fill Cap/Plug" instructions below.

1. Be sure engine is upright and level.
2. Unscrew oil fill cap/dipstick from oil filler tube and wipe dipstick clean. See Figures 8 and 9.
3. Screw oil fill cap/dipstick back into oil filler tube. Tighten securely.
4. Unscrew and remove oil fill cap/dipstick from oil filler tube. Note oil level. If oil reading on dipstick is below "ADD" mark, slowly add oil to reach "FULL" level. See Figure 7 on page 4. Afterward, continue reading instructions below.
5. Screw oil fill cap/dipstick back into oil filler tube. Tighten securely.
6. Wipe away any spilled oil.

NOTE

To change oil for engines with an oil fill cap/dipstick, see "B. Changing Oil" instructions on page 17.

II. Oil Fill Cap/Plug

If your engine does NOT have an oil fill cap/dipstick, go to step 1. If your engine has an oil fill cap/dipstick, see "I. Oil Fill Cap/Dipstick" instructions above.

1. Be sure engine is upright and level.
2. Clean area around oil fill cap/plug. See Figure 9.
3. Unscrew oil fill cap/plug.
4. Add oil to overflow point, making sure to avoid spilling.
5. Screw oil fill cap/plug back into oil fill hole. Tighten securely.
6. Wipe away any spilled oil.

NOTE

To change oil for engines with an oil fill cap/plug, see "B. Changing Oil" instructions on page 17.

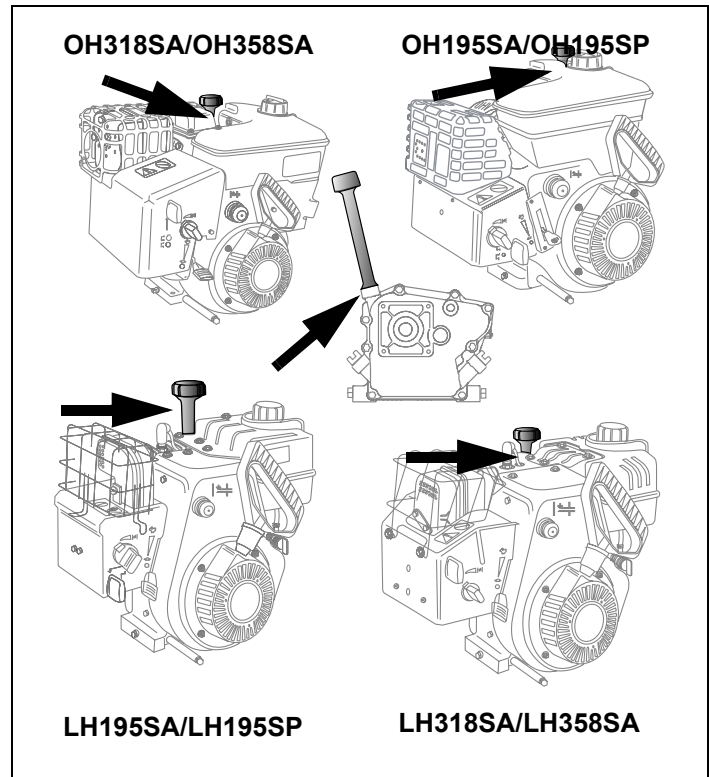

Figure 8. Oil Fill Cap/Dipstick Locations

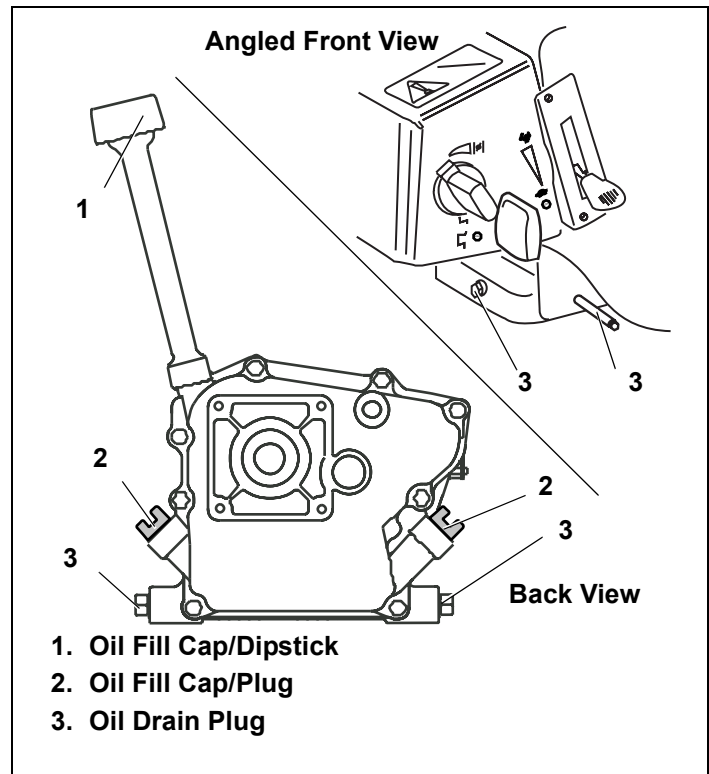

Figure 9. Oil Fill/Drain Locations

C. Check the Following Items

NOTE

Be sure equipment is in **neutral** before attempting to start (see equipment manufacturer's instructions).

1. Be sure ignition switch on engine or equipment is in "ON", "RUN" or "START" position. See Figures 10, 11 and 12.

Or

Insert ignition key, if present (see equipment manufacturer's instructions) into ignition key slot in carburetor cover. DO NOT turn ignition key. Be sure ignition key snaps into place. See Figures 10 and 11.

2. Be sure fuel valve, if present (see equipment manufacturer's instructions) is open. See Figure 13.
3. Check engine and equipment before each operation for loose nuts, bolts and attachments; keep these items tightened.

D. Check the Item Descriptions

The item descriptions listed below are for all 4-Cycle Horizontal Crankshaft Snow King Engine Models. See Figure 14 on page 7.

1. Control Lever
2. Oil Drain Plug
3. Choke
4. Ignition Key or Ignition Switch
5. Carburetor Cover
6. Muffler (with Muffler Guard, if equipped)
7. Oil Fill Cap/Dipstick
8. Spark Plug Cap
9. Fuel Fill Cap
10. Starter Cord Handle
11. Fuel Valve
12. Primer Bulb
13. Recoil Starter/Flywheel Guard

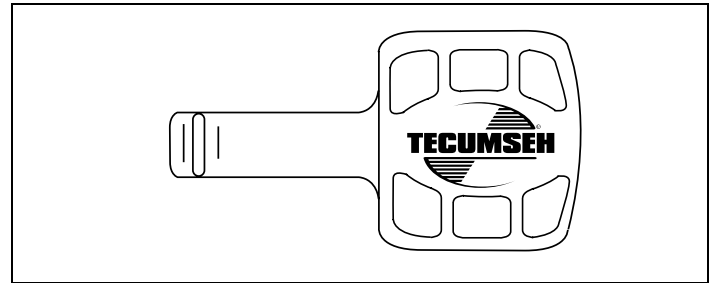

Figure 10. Ignition Key

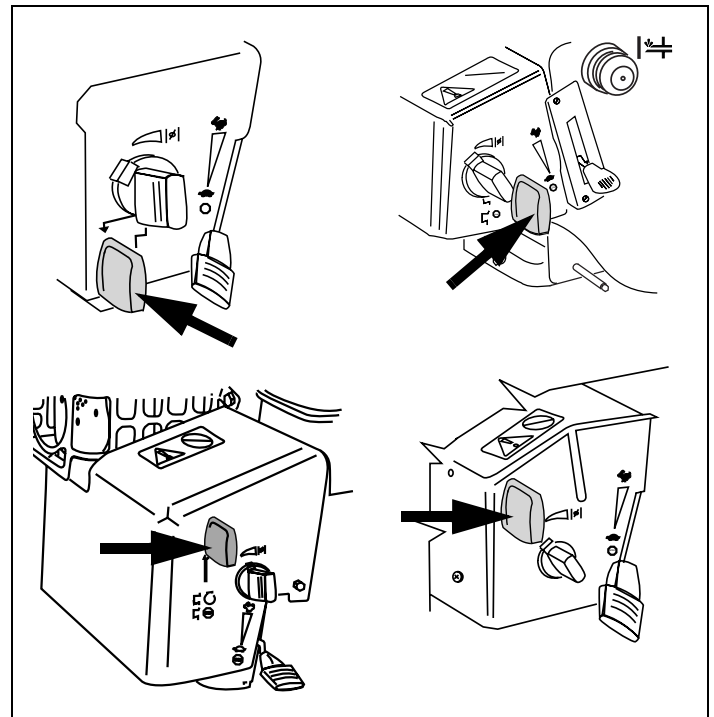

Figure 11. Possible Ignition Key Locations

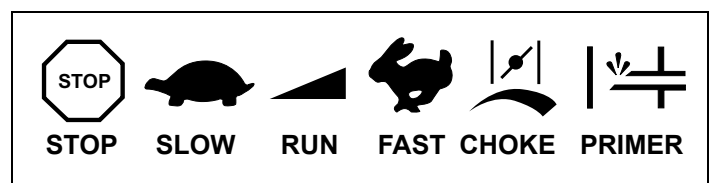

Figure 12. Typical Engine Symbols

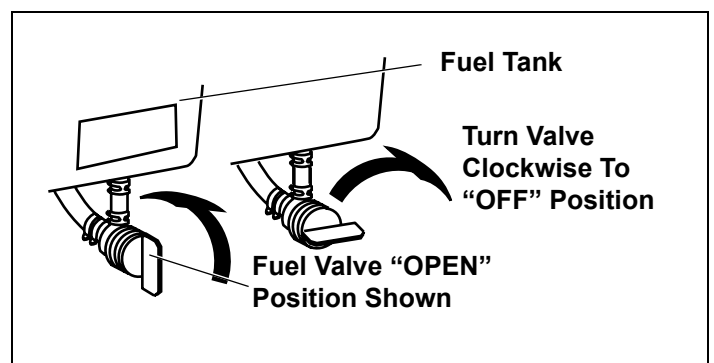

Figure 13. Fuel Valve Positions

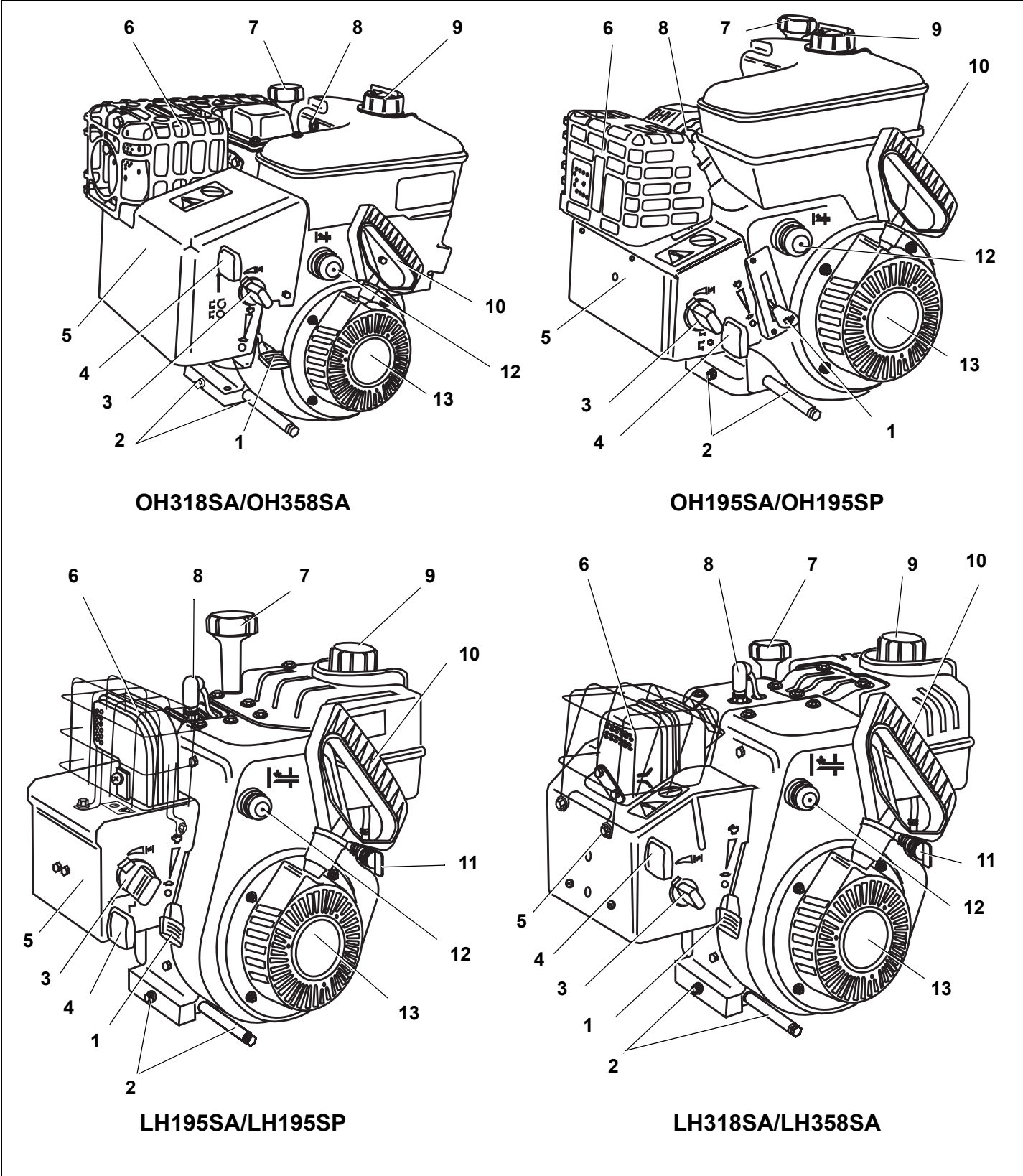

Figure 14. 4-Cycle Snow Engine Components

E. Filling Fuel Tank

⚠ WARNING

An adult should fuel this engine. NEVER allow children to refuel this engine. Gasoline (fuel) vapors are highly flammable and can explode. Fuel vapors can spread and be ignited by a spark or flame many feet away from engine. To prevent injury or death from fuel fires, follow these instructions:

1. Stop engine and allow it to cool before refueling.
2. Be sure engine is outdoors and in a well-ventilated area.
3. Clean area around fuel fill cap and remove fuel fill cap. See Figure 14 on page 7. Afterward, continue reading instructions below.

NOTE

For recommended fuel, see Table 3 on page 4. See "III. Oil and Fuel Specifications" instructions on page 4.

4. Using an approved red GASOLINE container, add fuel slowly, being careful to avoid spilling. DO NOT overfill fuel tank. Leave space in the tank to allow fuel to expand without overflowing.
5. Replace anti-splash fuel fill cap securely and wipe up spilled fuel before starting engine. If fuel is spilled DO NOT start engine. Move machine away from area of spillage. Avoid creating any source of ignition until fuel vapors are gone.

NOTE

Replace a damaged or missing fuel fill cap only with a genuine Tecumseh replacement anti-splash fuel fill cap. Failure to do so may **VOID YOUR WARRANTY**. See Figure 15.

6. Be sure fuel valve, if present (see equipment manufacturer's instructions) is open. See Figure 17.

F. Electrical Power

NOTES

When connecting power cord, always connect power cord to switch box on engine first; then into outlet. See Figure 17.

For european 220V A.C. applications use an appropriate grounded extension lead available locally.

Determine what type of power source outlet you will be connecting the power cord to, before you start your engine. See "A. Engines with Electric Starters" instructions on page 10.

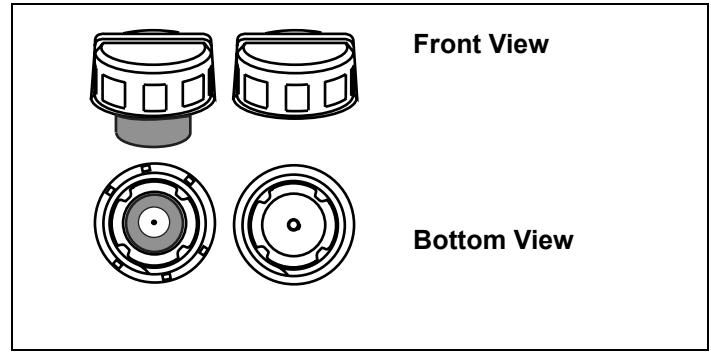

Figure 15. Possible Anti-Splash Fuel Fill Cap(s)

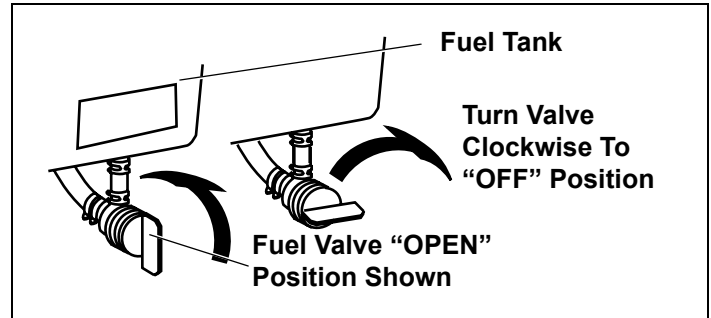

Figure 16. Fuel Valve Positions

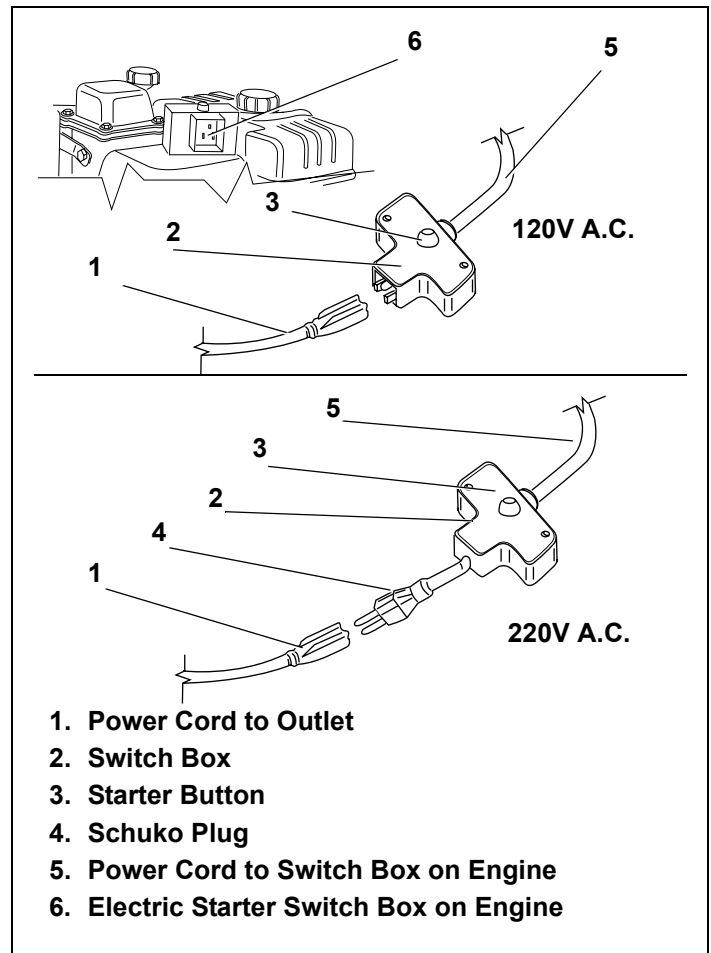

Figure 17. Electric Starter Connections

V. Starting Your Engine

⚠ WARNING

An adult should start the engine. Only allow children to start engine if an adult has determined they are experienced and capable of such operation.

⚠ WARNING

If you are unable to start this engine after following instructions in this manual, contact your Authorized Tecumseh Servicing Dealer. To avoid serious burn injuries or damage to your engine, DO NOT attempt to start or troubleshoot this engine in any other way. For example:

- DO NOT use starting fluid.
- DO NOT spray flammable vapors into carburetor.
- DO NOT put flammable liquids into carburetor.
- DO NOT operate engine or pull on starter rope with spark plug removed. Fuel can spray from spark plug hole and ignite.

NOTE

If engine is remotely controlled, (see equipment manufacturer's instructions) your equipment may have one or more of the following engine symbols. See Figure 18.

This section contains starting instructions for several different types of engines. In order to locate the instructions that apply to your engine, first determine what type of starter you have. If you have an electric starter, see "A. Engines with Electric Starters" instructions on page 10. If you have a manual recoil starter, see "B. Engines with Recoil Starters" instructions on page 13.

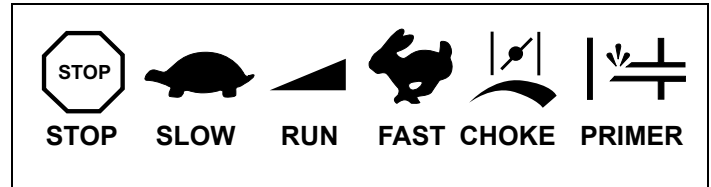

Figure 18. Typical Engine Symbols

A. Engines with Electric Starters

If you have a recoil starter, see “B. Engines with Recoil Starters” instructions on page 13.

WARNING

Some electric starters are equipped with a 120V A.C. Three-Wire Power Cord and Plug designed to operate on a 120V A.C. household current. It must be properly grounded at all times to avoid the possibility of injury or death from electrical shock.

- Determine if your house wiring has a Ground Fault Interrupted (G.F.I.) Three-Wire Grounded System; if you are not sure ask a Licensed Electrician.
 - If your house wiring does not have a G.F.I. Three-Wire Grounded System, **DO NOT USE THIS ELECTRIC STARTER UNDER ANY CONDITION.**
 - If your house wiring is grounded and a G.F.I. Three-Prong Wall Receptacle is not available at the location where your starter will be used, one must be installed by a Licensed Electrician **BEFORE USING THE ELECTRIC STARTER.**
- To avoid carbon monoxide poisoning, be sure engine is outdoors in a well-ventilated area.
 - Be sure fuel valve, if present (see equipment manufacturer’s instructions) is open and all switches are on. See Figure 19.

NOTES

If your engine is equipped with a 12V battery-operated electric starter, proceed to step 4.

When connecting power cord, always connect power cord to switch box on engine first; then into outlet. See Figure 20.

For european 220V A.C. applications use an appropriate grounded extension lead available locally.

- Connect power cord to switch box on engine. See Figure 20.
- Plug end of power cord into outlet.

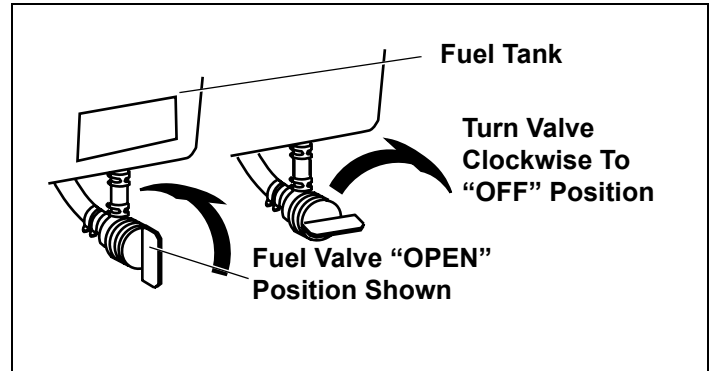

Figure 19. Fuel Valve Positions

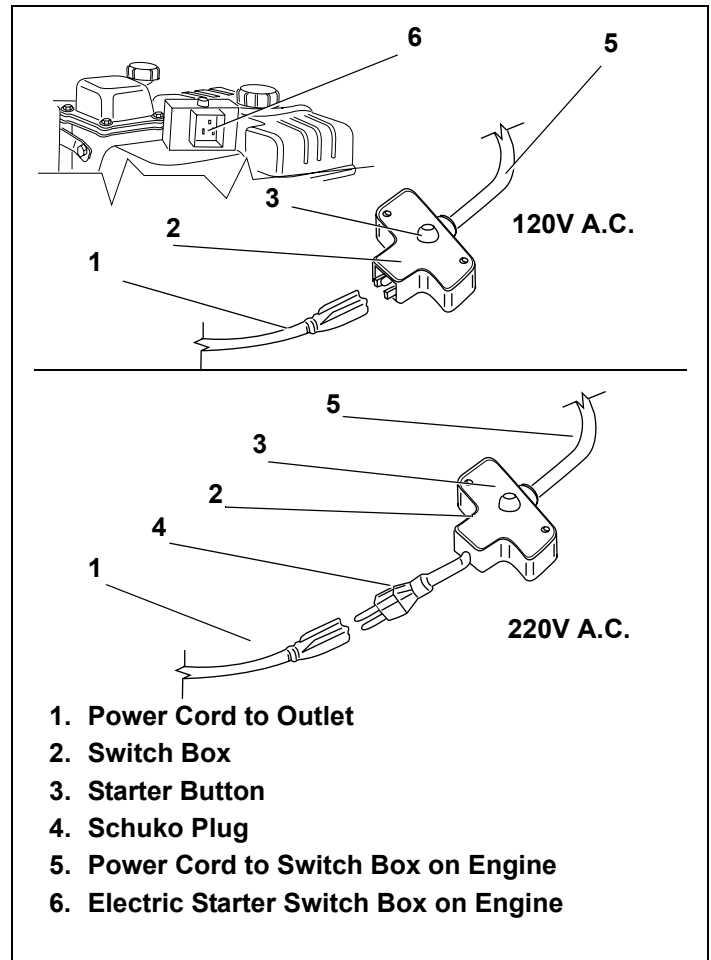

Figure 20. Electric Starter Connections

5. Move engine speed control to “FAST” position. See Figures 21 and 22.
6. Set choke control to “FULL CHOKE” position (see equipment manufacturer’s instructions). See Figure 24 on page 12. Afterward, continue reading instructions below.
7. Hold the primer bulb in for one full second each time you press it. See Figure 23.
 - Make sure you cover vent hole with your thumb.
 - Repeat twice for a total of three primes.

NOTES

DO NOT operate an electric starter for more than 5 seconds each attempt.

DO NOT use primer bulb to restart a warm engine after a short shutdown. Doing so will flood the engine and may result in equipment malfunction.

If restarting a warm engine after a short shutdown, move engine speed control to “FAST” position and move choke control to “NO CHOKE” position. See Figures 21, 22 and 24. Afterward, continue reading instructions below.

8. Push starter button or turn ignition switch key (see equipment manufacturer’s instructions) to start engine. See “C. Check the Following Items” instructions on page 6. Afterward, continue reading instructions below.

NOTE

If engine fails to start after 3 attempts repeat steps 1 thru 8.

9. When engine starts:
 - a. Release starter button or ignition switch key. See Figure 20 on page 10. Afterward, continue reading instructions below.
 - b. Momentarily move choke control to “1/2 CHOKE” position until engine runs smoothly. See Figure 24 on page 12. Afterward, continue reading instructions below.
 - c. Next, move choke control to “NO CHOKE” position.
10. Move engine speed control to desired speed in “RUN” range. See Figures 21 and 22.

NOTES

If engine starts but falters when choke control is moved to “NO CHOKE” position:

- a. Momentarily move choke control back to “FULL CHOKE” position.
- b. Next, move choke control to “1/2 CHOKE” position until engine runs smoothly.
- c. Finally, move choke control to “NO CHOKE” position.

If engine dies after choke control is moved to “NO CHOKE” position repeat steps 5 thru 10 to restart engine.

11. If engine fires but does not continue to run, move choke control to “NO CHOKE” position and start engine. See Figure 24 on page 12. Afterward, continue reading instructions.

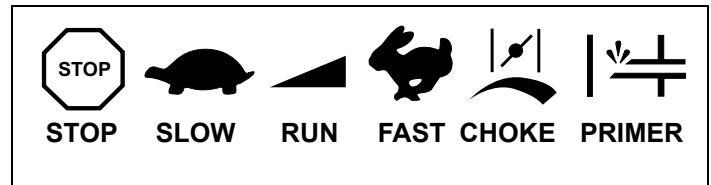

Figure 21. Typical Engine Symbols

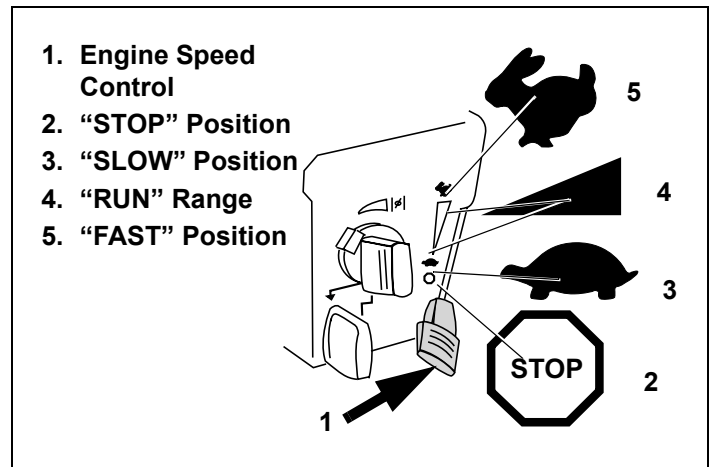

Figure 22. Engine Speed Control Positions

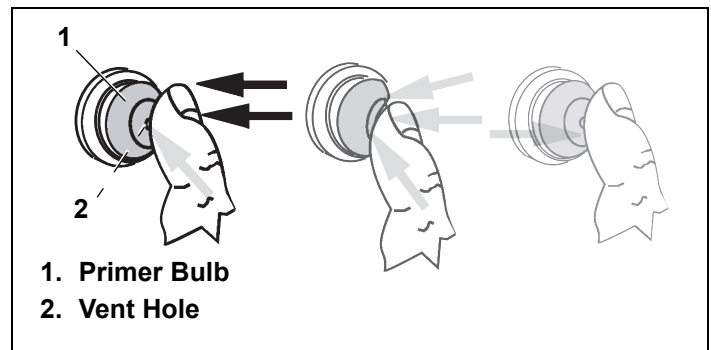

Figure 23. Pressing Primer Bulb

12. If engine fails to start after 3 attempts in the “NO CHOKE” position, move choke control to “FULL CHOKE” position and start engine.

NOTE

When disconnecting power cord, always disconnect power cord from outlet first; then disconnect power cord from switch box on engine. See Figure 20 on page 10. Afterward, continue reading instructions below.

13. Disconnect power cord from outlet. See Figure 20 on page 10. Afterward, continue reading instructions below.
14. Disconnect power cord from switch box on engine. See Figure 20 on page 10. Afterward, continue reading instructions below.
15. If engine does not start after following steps 1 thru 12, contact your Authorized Tecumseh Servicing Dealer. DO NOT attempt to start or troubleshoot this engine in any other way.

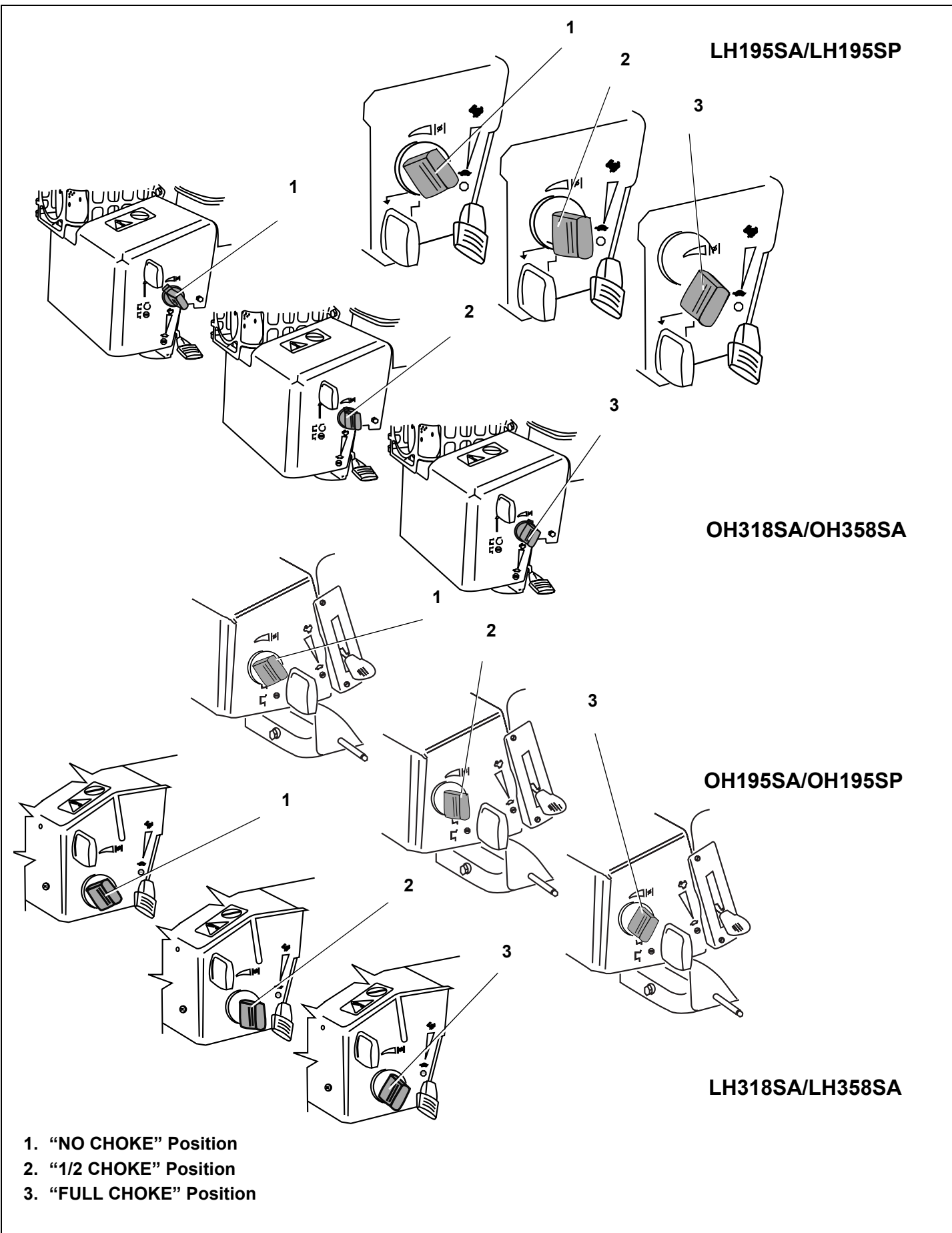

Figure 24. Choke Control Positions

B. Engines with Recoil Starters

If you have an electric starter, see “A. Engines with Electric Starters” instructions on page 10.

⚠ WARNING DO NOT pull starter rope with engine running. Doing so may **VOID YOUR WARRANTY.**

1. To avoid carbon monoxide poisoning, be sure engine is outdoors in a well-ventilated area.
2. Be sure fuel valve, if present (see equipment manufacturer’s instructions) is open and all switches are on. See Figure 25.
3. Move engine speed control to “FAST” position. See Figures 26 and 27.
4. Set choke control to “FULL CHOKE” position (see equipment manufacturer’s instructions). See Figure 24 on page 12. Afterward, continue reading instructions below.
5. Hold the primer bulb in for one full second each time you press it. See Figure 28.
 - Make sure you cover vent hole with your thumb.
 - Repeat twice for a total of three primes.

NOTES

DO NOT use primer bulb to restart a warm engine after a short shutdown. Doing so will flood the engine and may result in equipment malfunction.

If restarting a warm engine after a short shutdown, move engine speed control to “FAST” position and move choke control to “NO CHOKE” position. See Figures 24, 26 and 27 starting on page 12. Afterward, continue reading instructions below.

6. Operate equipment control to release engine brake or clutch, if present (see equipment manufacturer’s instructions).

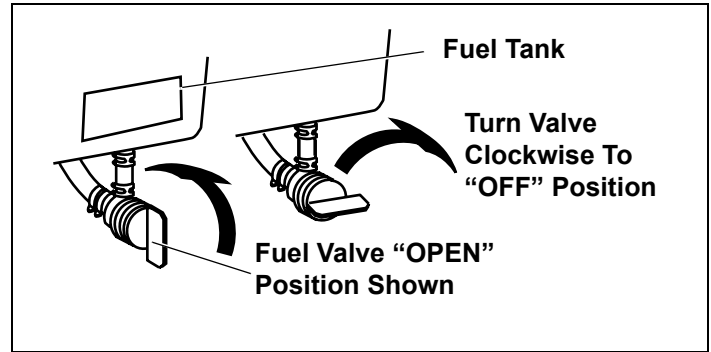

Figure 25. Fuel Valve Positions

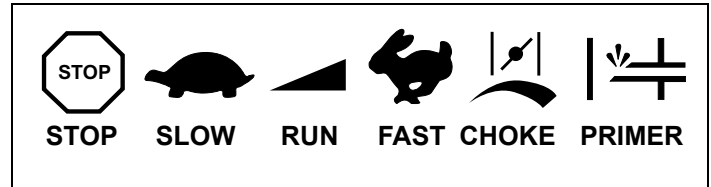

Figure 26. Typical Engine Symbols

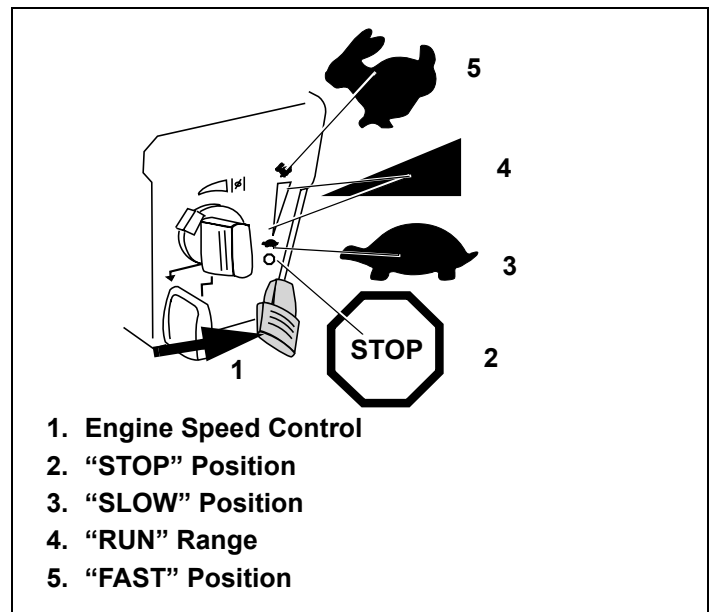

Figure 27. Engine Speed Control Positions

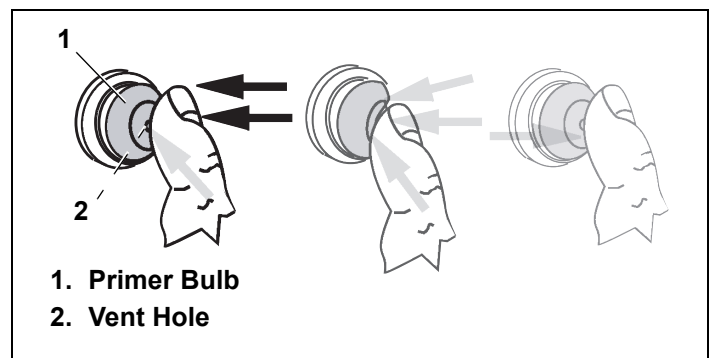

Figure 28. Pressing Primer Bulb

WARNING

When pulling starter rope, the rope can unexpectedly jerk back toward engine causing serious injury. To avoid this risk, carefully follow these instructions:

7. Grasp starter cord handle. See Figure 29.
 - a. Pull rope out slowly until you feel drag.
 - b. Without allowing the rope to retract, continue pulling rope with one rapid full arm stroke.
 - c. Return rope *slowly* to original position.

NOTES

Following the instructions listed in the steps above avoids potential damage to the recoil mechanism.

If recoil starter handle is frozen and will not operate engine, proceed as follows:

- a. *Pull as much rope out of starter as possible.*
 - b. *Release starter handle and let it snap back against starter to break up ice; these two steps should **ONLY** be done **WHEN** starter is **FROZEN**.*
 - c. *If engine fails to start after 3 attempts repeat steps 1 thru 7 and try again.*
8. When engine starts:
 - a. Momentarily move choke control to "1/2 CHOKE" position until engine runs smoothly. See Figure 24 on page 12. Afterward, continue reading instructions below.
 - b. Next, move choke control to "NO CHOKE" position.
 - c. Finally, move engine speed control to desired speed in "RUN" range. See Figures 26 and 27 on page 13. Afterward, continue reading instructions below.

NOTES

If engine starts but falters when choke control is moved to "NO CHOKE" position:

- a. *Momentarily move choke control back to "FULL CHOKE" position.*
 - b. *Next, move choke control to "1/2 CHOKE" position until engine runs smoothly.*
 - c. *Finally, move choke control to "NO CHOKE" position.*

If engine dies after choke control is moved to "NO CHOKE" position repeat steps 3 thru 8 to restart engine.

9. If engine fires but does not continue to run, move choke control to "NO CHOKE" position and start engine. See Figure 24 on page 12. Afterward, continue reading instructions below.
10. If engine fails to start after 3 attempts in the "NO CHOKE" position, move choke control to "FULL CHOKE" position and start engine.
11. If engine does not start after following steps 1 thru 10, contact your Authorized Tecumseh Servicing Dealer. **DO NOT** attempt to start or troubleshoot this engine in any other way.

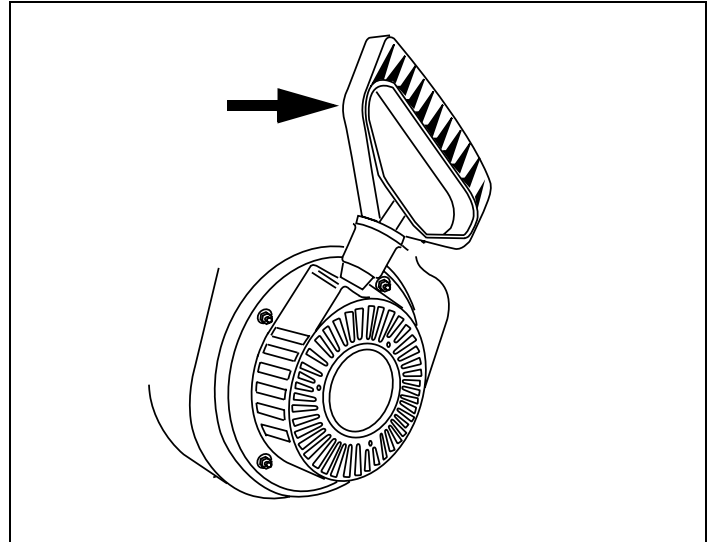

Figure 29. Recoil Starter Handle

VI. Stopping Your Engine and Short-Term Storage

Stop engine according to equipment manufacturer's instructions.

⚠ WARNING

To avoid unsupervised operation of an engine, especially by children, NEVER leave it unattended when it is running. Always turn off the engine after use and remove ignition key, if provided.

⚠ WARNING

NEVER store the engine with fuel in the fuel tank inside a building with potential sources of ignition such as hot water and space heaters, clothes dryers, electric motors, etc.

A. Stop Engine

NOTE

Run engine for a few minutes to help dry off any moisture on engine before proceeding to Step 1.

1. Move equipment control, if present (see manufacturer's instructions), engine control lever or ignition switch to "STOP" or "OFF" position. See Figure 31.

⚠ WARNING

To avoid unsupervised operation of an engine, especially by children, NEVER leave it unattended when it is running. Always turn off the engine after use and remove ignition key, if provided.

2. Remove ignition key, if provided (see manufacturer's instructions). See Figures 30 and 32.

NOTE

Removing key will reduce the possibility of unauthorized starting of the engine while equipment is not in use.

3. Be sure fuel valve, if present (see equipment manufacturer's instructions) is in "OFF" position. See Figure 34 on page 16.

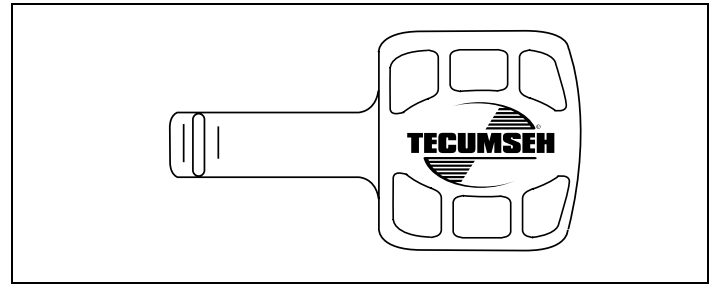

Figure 30. Ignition Key

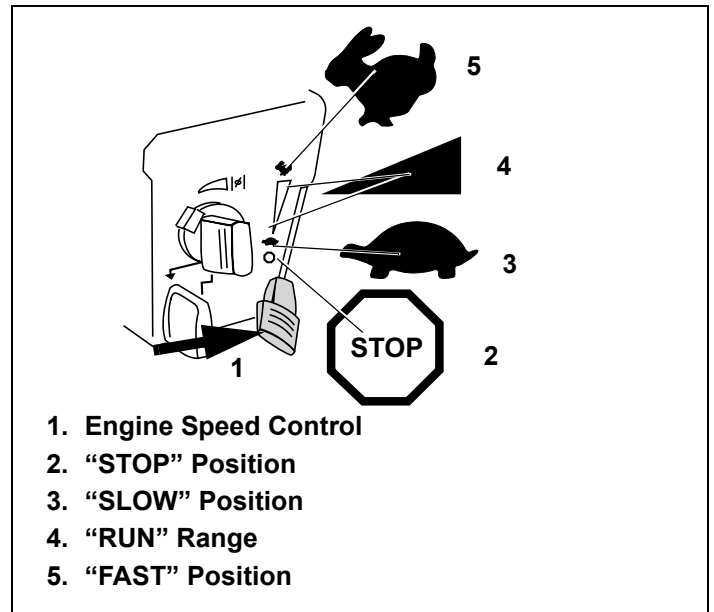

Figure 31. Engine Speed Control Positions

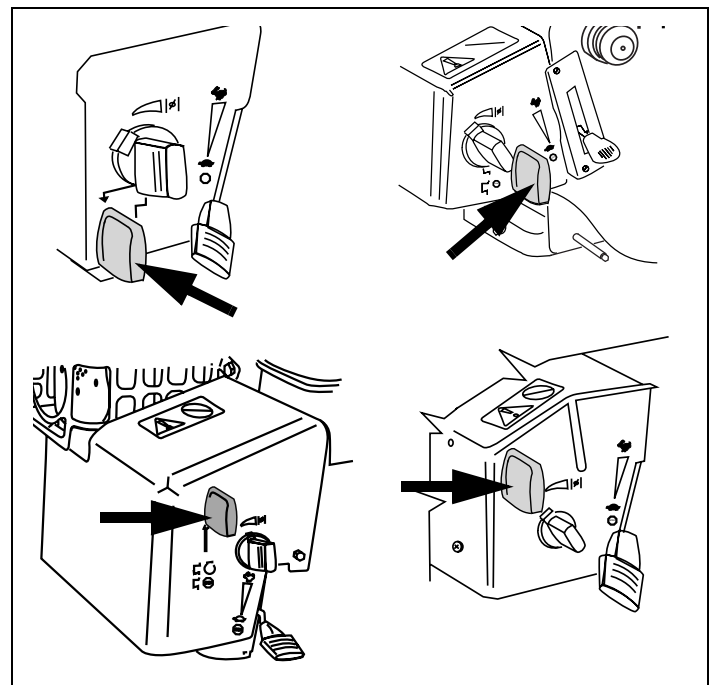

Figure 32. Possible Ignition Key Locations

B. After Engine is Stopped

⚠ WARNING To prevent possible freeze-up of engine controls, follow instructions with engine STOPPED, listed below.

1. Wipe all snow and moisture from engine control lever and choke areas.
2. Move equipment control, if present (see manufacturer's instructions), engine control lever or ignition switch back and forth several times and leave control in "STOP" or "OFF" position. See Figure 33.
3. Move engine choke back and forth several times and leave in the "FULL CHOKE" position. See Figure 24 on page 12. Afterward, continue reading instructions below.
4. Be sure fuel valve, if present (see equipment manufacturer's instructions) is in "OFF" position. See Figure 34.

⚠ WARNING NEVER store the engine with fuel in the fuel tank inside a building with potential sources of ignition such as hot water and space heaters, clothes dryers, electric motors, etc.

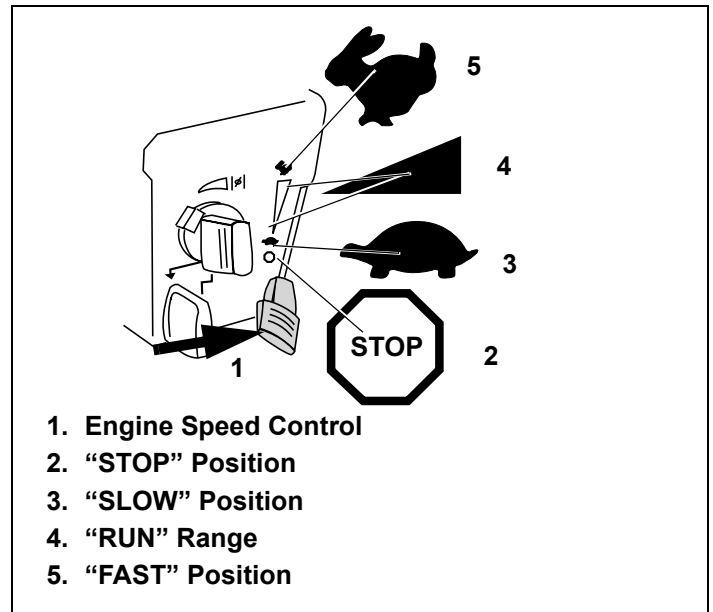

Figure 33. Engine Speed Control Positions

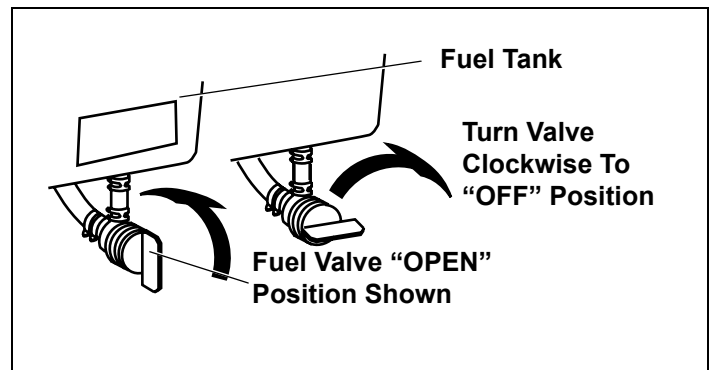

Figure 34. Fuel Valve Positions

VII. Maintenance

⚠ WARNING

An adult should perform maintenance on this engine. Only allow children to perform maintenance if an adult has determined they are experienced and capable of such operation.

⚠ WARNING

To prevent accidental starting when working on equipment, always:

- Carefully disconnect spark plug wire and keep it away from spark plug. See Figures 35 and 36. See "G. Avoid Accidental Starts" instructions on page 2. Afterward, continue reading instructions below.
 - Keep the disconnected spark plug wire securely away from metal parts where arcing could occur.
 - Carefully attach the spark plug wire to the grounding post, if provided.
- Disconnect battery at negative terminal first, if engine is equipped with a D.C. electric starter.
- Turn all engine switches to "OFF" position.
- Remove ignition key, if provided.

NOTES

When disconnecting power cord, always disconnect power cord from outlet first; then disconnect power cord from switch box on engine. See Figure 37.

When connecting power cord, always connect power cord to switch box on engine first; then into outlet. See Figure 37.

A. Remote Choke

See equipment manufacturer's instructions and contact an Authorized Tecumseh Servicing Dealer.

B. Changing Oil

To avoid engine damage, it is important to:

- Check oil level before each use and every 5 operating hours when engine is warm. See "A. Checking Oil Level" instructions on page 4. Afterward, continue reading instructions below.
- Change oil after first 2 operating hours and every 25 operating hours thereafter. Engine should still be warm but NOT hot from recent use.

NOTES

To check oil on engines with an oil fill cap/dipstick, see "I. Oil Fill Cap/Dipstick" instructions on page 5.

To check oil on engines with an oil fill cap/plug, see "II. Oil Fill Cap/Plug" instructions on page 5.

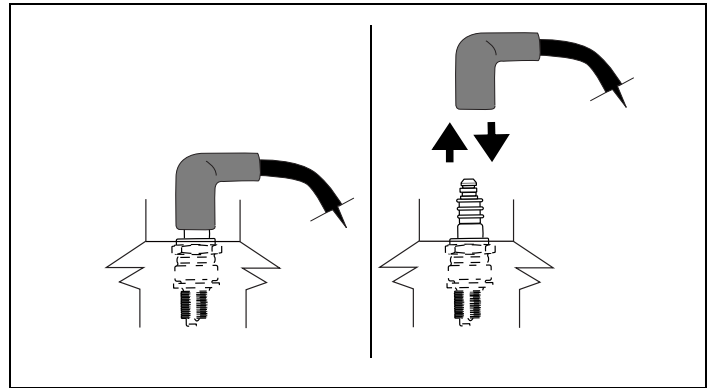

Figure 35. Disconnecting/Connecting Spark Plug

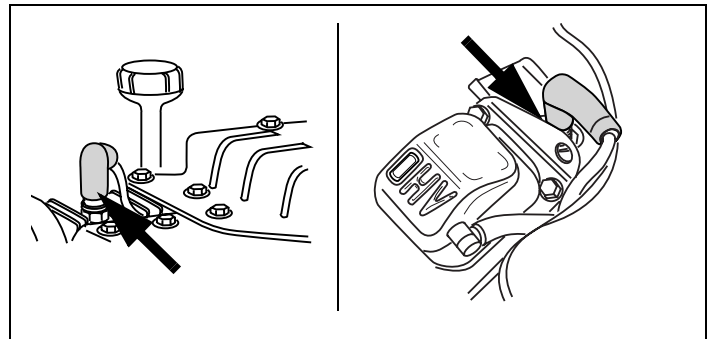

Figure 36. Typical Spark Plug Connection

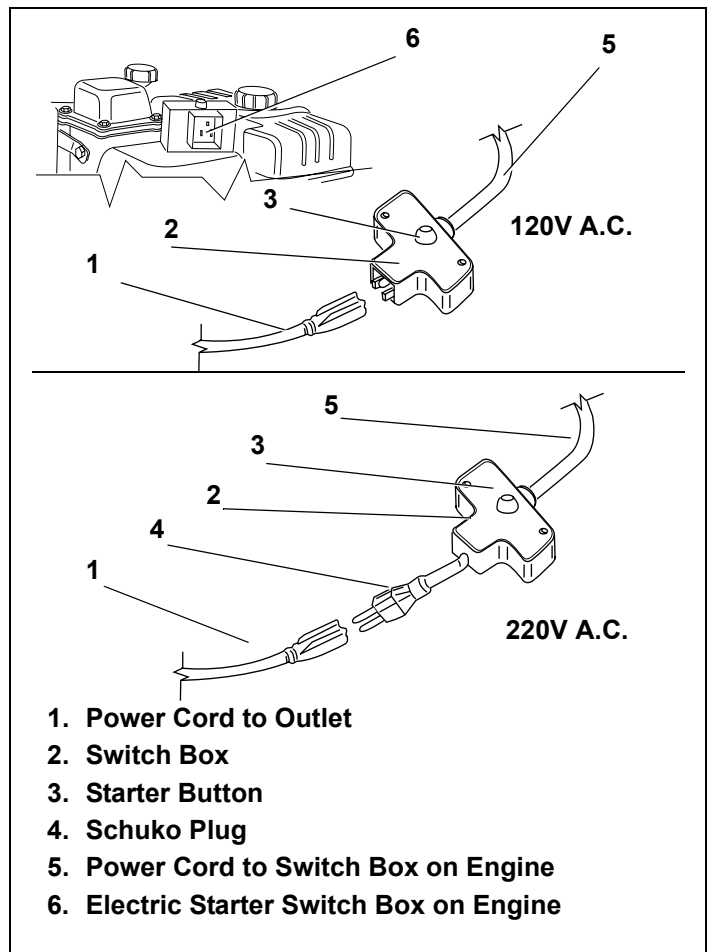

Figure 37. Electric Starter Connections

I. Oil Fill Cap/Dipstick

If your engine has an oil fill cap/dipstick go to step 1. If your engine does NOT have an oil fill cap/dipstick, see "II. Oil Fill Cap/Plug" instructions on page 20.

1. Carefully disconnect spark plug wire and keep it away from spark plug. See Figures 38 and 39. See "G. Avoid Accidental Starts" instructions on page 2. Afterward, continue reading instructions below.

- Keep the disconnected spark plug wire securely away from metal parts where arcing could occur.
- Carefully attach the spark plug wire to the grounding post, if provided.

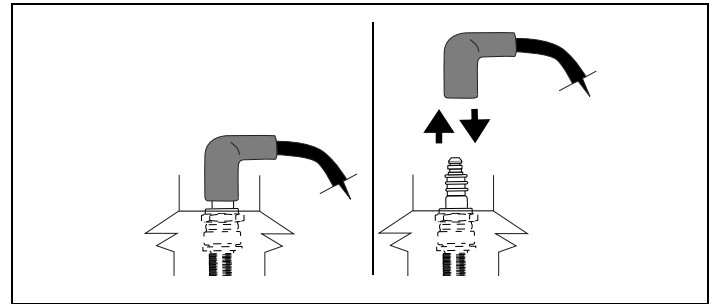

Figure 38. Disconnecting/Connecting Spark Plug

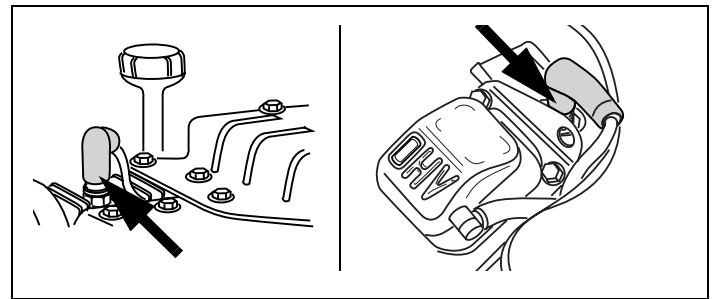

Figure 39. Typical Spark Plug Connection

2. Be sure fuel fill cap is on and tightened securely. See Figure 40. See Figure 14 on page 7. Afterward, continue reading instructions below.

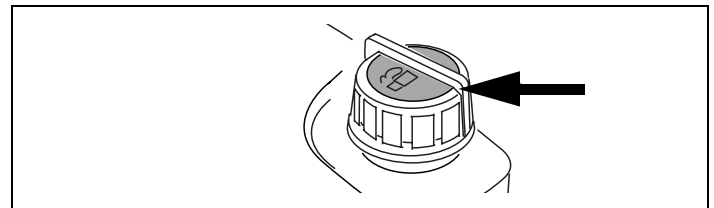

Figure 40. Fuel Fill Cap

3. Be sure you find the correct oil drain plug location, if present (see equipment manufacturer's instructions). See Figure 41. See Figure 14 on page 7. Afterward, continue reading instructions below.

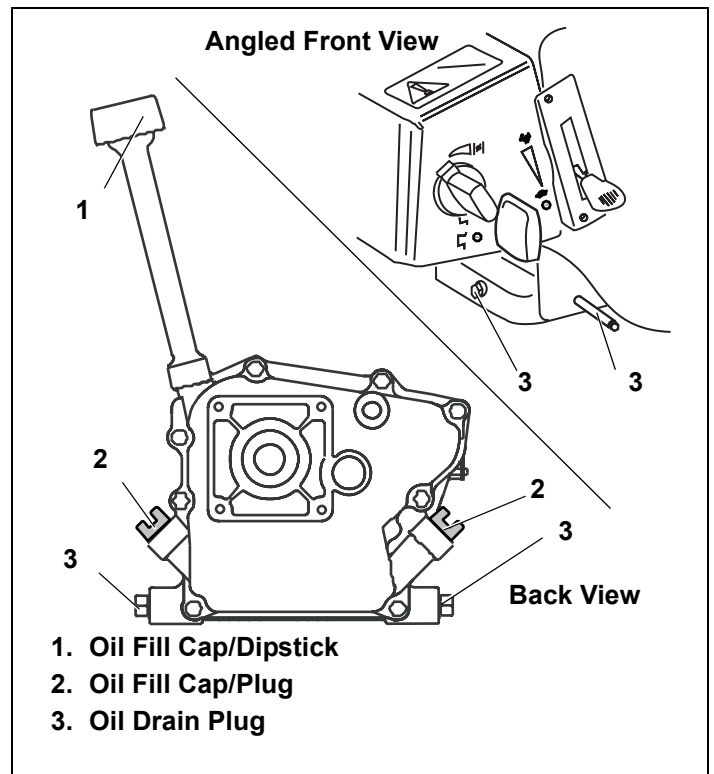

Figure 41. Oil Fill/Drain Locations

4. Clean area around oil drain plug.

5. Place approved recyclable oil container under oil drain plug, if present. See Figure 41 on page 18. Afterward, continue reading instructions below.
6. Remove oil drain plug, if present.
7. Tip engine to position the oil flow, so it will drain from the lowest point on the engine (see equipment manufacturer's instructions).
8. Drain oil into an approved recyclable oil container.



NOTE

Used oil must be disposed of at a proper collection center.

9. Install oil drain plug and tighten securely.
10. Clean area around oil drain plug. See Figure 41 on page 18. Afterward, continue reading instructions below.
11. Remove oil fill cap/dipstick. See Figure 42.
12. Fill with recommended oil. See Figure 43. See "III. Oil and Fuel Specifications" instructions on page 4. See Table 1 on page 4. Afterward, continue reading instructions below.

NOTES

DO NOT overfill oil filler. Doing so may result in oil carry-over to the equipment and cause malfunction or damage.

DO NOT allow oil level to fall below the "ADD" mark on oil fill cap/dipstick. Doing so may result in equipment malfunction or damage.

Contact your Authorized Tecumseh Servicing Dealer for Tecumseh Oil.

13. Wipe away any spilled oil.
14. Install oil fill cap/dipstick. Tighten securely. See Figure 42.
15. Carefully disconnect spark plug wire from grounding post, if provided. See Figures 38 and 39 on page 18. See "G. Avoid Accidental Starts" instructions on page 2. Afterward, continue reading instructions below.
16. Carefully re-connect spark plug wire to spark plug. See Figures 38 and 39 on page 18.

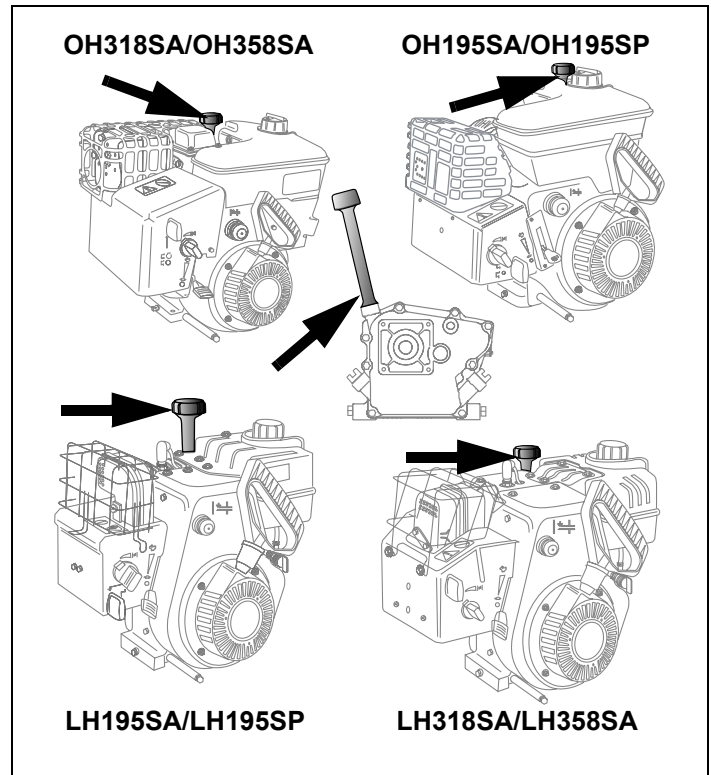

Figure 42. Oil Fill Cap/Dipstick Locations

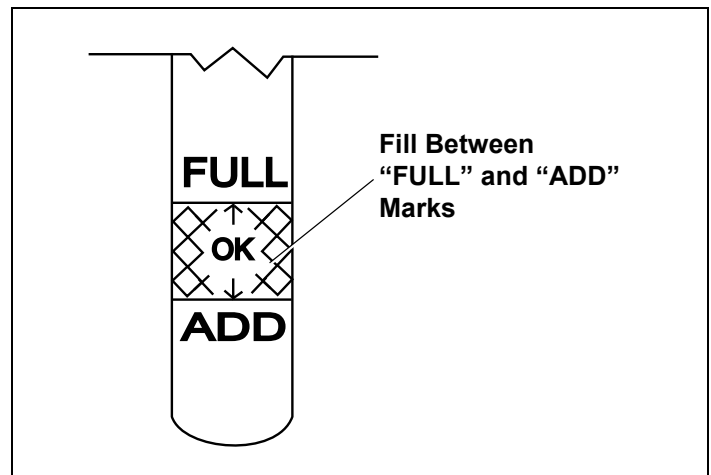

Figure 43. Engine Oil Level

II. Oil Fill Cap/Plug

If your engine does NOT have an oil fill cap/dipstick, go to step 1. If your engine has an oil fill cap/dipstick, see "I. Oil Fill Cap/Dipstick" instructions on page 18.

1. Carefully disconnect spark plug wire and keep it away from spark plug. See Figures 44 and 45. See "G. Avoid Accidental Starts" instructions on page 2. Afterward, continue reading instructions below.
 - Keep the disconnected spark plug wire securely away from metal parts where arcing could occur.
 - Carefully attach the spark plug wire to the grounding post, if provided.

2. Be sure fuel fill cap is on and tightened securely. See Figure 46.

3. Be sure you find the correct oil drain plug location (see equipment manufacturer's instructions). See Figure 47.
4. Clean area around oil drain plug.

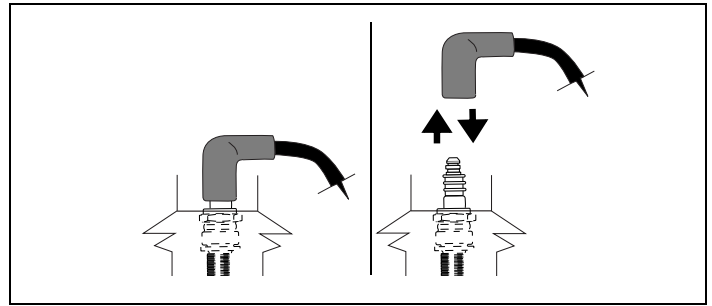

Figure 44. Disconnecting/Connecting Spark Plug

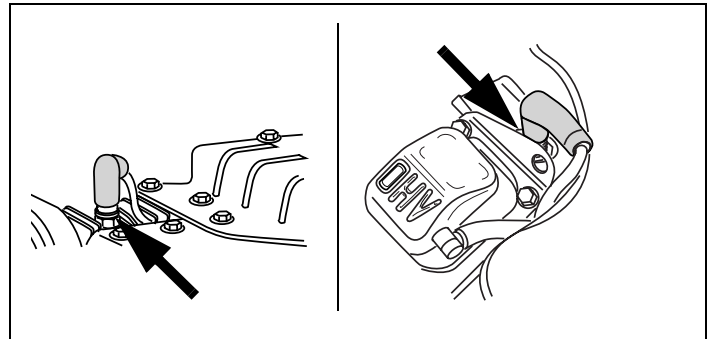

Figure 45. Typical Spark Plug Connection

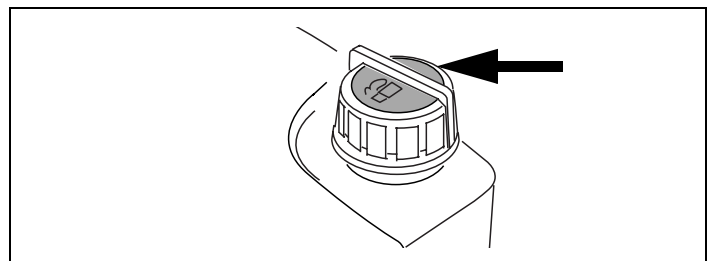

Figure 46. Fuel Fill Cap

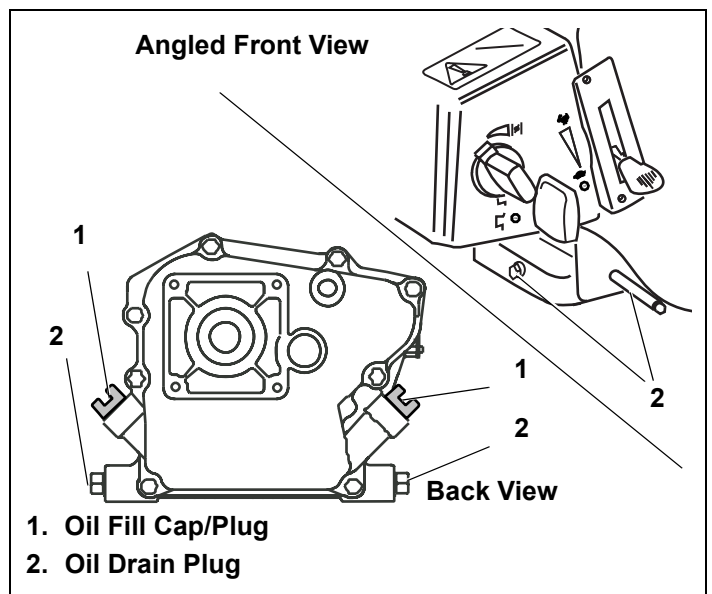

Figure 47. Oil Fill/Drain Locations

5. Place approved recyclable oil container under oil drain plug. See Figures 47 and 48 starting on page 20. Afterward, continue reading instructions below.
6. Tip engine to position the oil drain plug at the lowest point on the engine (see equipment manufacturer's instructions).



7. Remove oil drain plug and drain oil into an approved recyclable oil container.

NOTE

Used oil must be disposed of at a proper collection center.

8. Install oil drain plug and tighten securely. See Figure 48.
9. Remove oil fill cap/plug from oil fill hole.
 - See Figures 47 and 48 starting on page 20. Afterward, continue reading instructions below.
 - See "III. Oil and Fuel Specifications" instructions on page 4. Afterward, continue reading instructions below.
 - See Table 1 on page 4. Afterward, continue reading instructions below.
10. Add oil to overflow point, making sure to avoid spilling and fill with recommended oil.

NOTES

DO NOT overfill oil filler. Doing so may result in oil carry-over to the equipment and cause malfunction or damage.

Contact your Authorized Tecumseh Servicing Dealer for Tecumseh Oil.

11. Wipe away any spilled oil.
12. Screw oil fill cap/plug back into oil fill hole. Tighten securely. See Figures 47 and 48 starting on page 20. Afterward, continue reading instructions below.
13. Carefully disconnect spark plug wire from grounding post, if provided. See Figure 49. See "G. Avoid Accidental Starts" instructions on page 2. Afterward, continue reading instructions below.
14. Carefully re-connect spark plug wire to spark plug. See Figure 50.

C. Spark Plug

Check spark plug yearly or every 100 operating hours.

1. Clean area around spark plug.
2. Remove and inspect spark plug.
3. Replace spark plug if porcelain is cracked or if electrodes are:
 - Pitted
 - Burned
 - Fouled with Deposits
4. Check electrode gap with wire feeler gauge and set gap to—.030 in. (0.76mm) if necessary. See Figure 51.
5. Install spark plug and tighten securely.

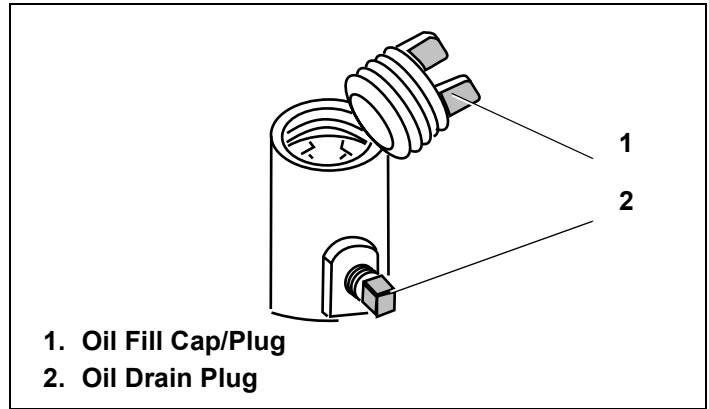

Figure 48. Oil Fill Cap/Plug and Oil Drain Plug

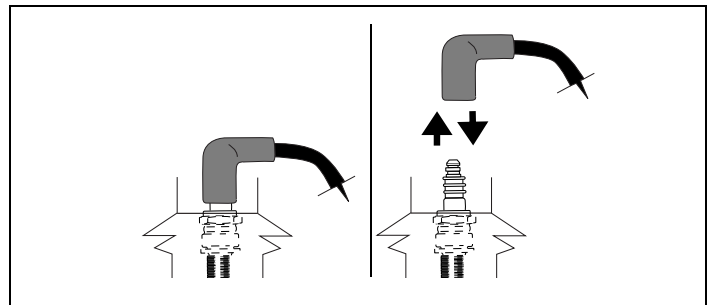

Figure 49. Disconnecting/Connecting Spark Plug

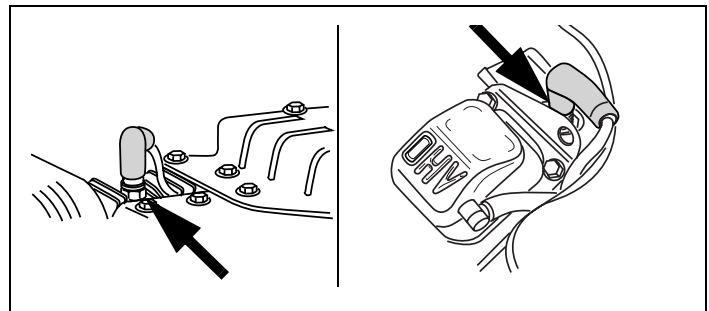

Figure 50. Typical Spark Plug Connection

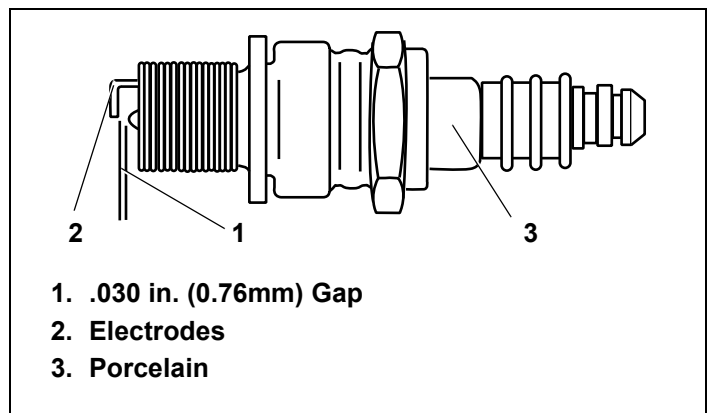

Figure 51. Resistor Spark Plug

NOTE

A resistor spark plug must be used for replacement. Contact your Authorized Tecumseh Servicing Dealer for a Tecumseh Resistor Spark Plug.

D. Adjustments

DO NOT make any engine adjustments. Factory settings are satisfactory for most conditions. If adjustments are needed, contact your Authorized Tecumseh Servicing Dealer.

E. Carburetor

If you think your carburetor needs adjusting, see your nearest Authorized Tecumseh Servicing Dealer. Engine performance should NOT be affected at altitudes up to 7,000 feet (**2,134 meters**). For operation at higher elevations, contact your Authorized Tecumseh Servicing Dealer.

F. Alternator (Optional)

For alternator related electrical problems such as:

- Inoperative Starter
- Discharged Battery
- Fuse Replacement
- Alternator Maintenance/Repairs

See your equipment manufacturer's instructions and an Authorized Tecumseh Servicing Dealer.

G. Engine Speed

⚠ WARNING

To avoid serious injury or death, DO NOT modify engine in any way.

Tampering with the governor setting can lead to a runaway engine and cause it to operate at unsafe speeds. NEVER tamper with factory setting of engine governor.

Running the engine faster than the speed set at the factory can be dangerous and will **VOID THE ENGINE WARRANTY**.

H. Removing Snow from Engine

After each use, remove snow from the areas listed. See Figure 52 on page 23. Afterward, continue reading instructions below.

- Oil Fill Cap/Dipstick
- Fuel Fill Cap
- Recoil Starter/Flywheel Screen
- Linkage
- Guards
- Spark Plug Connection (If visible).
- Electric Starter Switch Box, if present (see equipment manufacturer's instructions). See "A. Engines with Electric Starters" instructions on page 10. Afterward, continue reading instructions below.

NOTE

See equipment manufacturer's instructions for proper location of fuel fill cap and control lever.

Removing snow will ease operation of the recoil starter rope and reduce the risk of water contamination when opening fuel fill cap.

NOTE

For more information about recoil starters see "B. Engines with Recoil Starters" instructions on page 13.

VIII. Transporting Your Engine

⚠ WARNING

NEVER transport this engine inside another vehicle or in any enclosed space if there is any gasoline in the tank. Fuel vapor or spilled fuel may ignite.

⚠ WARNING

If there is fuel in the fuel tank, close the fuel valve, if equipped, and transport the engine upright in an open vehicle, such as an open trailer or open bed of a pickup truck.

If you DO NOT have an open vehicle and have to transport the engine upright in a closed vehicle, follow these steps for emptying the fuel tank before transporting:

1. Empty fuel tank by using a commercially available suction device designed for use with gasoline.

⚠ WARNING

2. Drain fuel into an approved red GASOLINE container, being careful to avoid spilling.
3. Run the engine until remaining fuel is consumed.

⚠ WARNING

NEVER leave the engine unattended when it is running and NEVER run engine in enclosed areas.

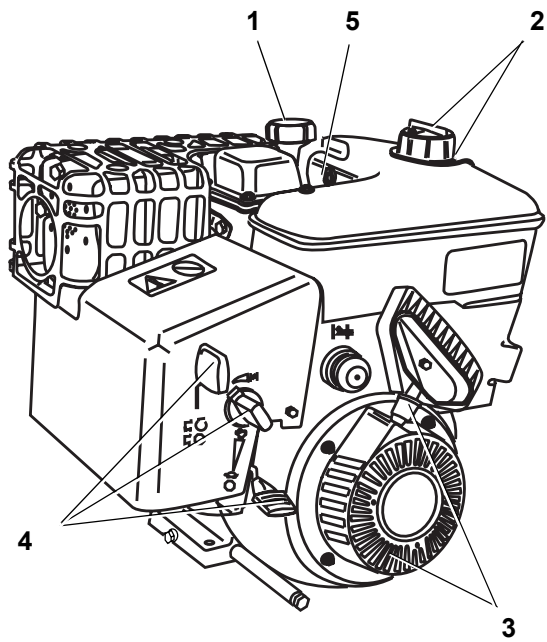

OH318SA/OH358SA

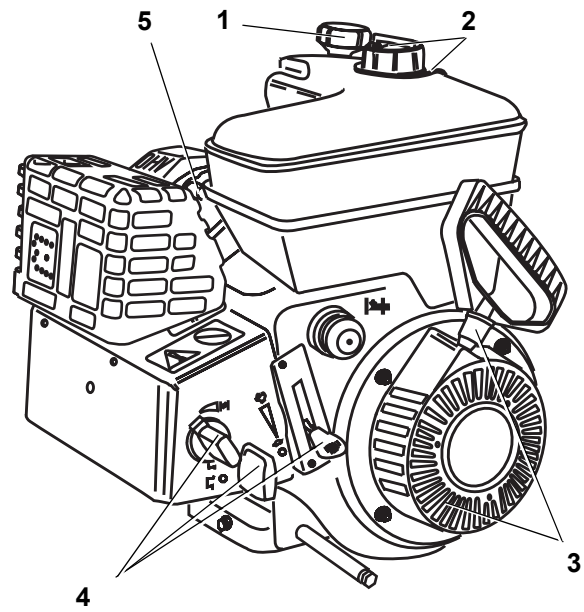

OH195SA/OH195SP

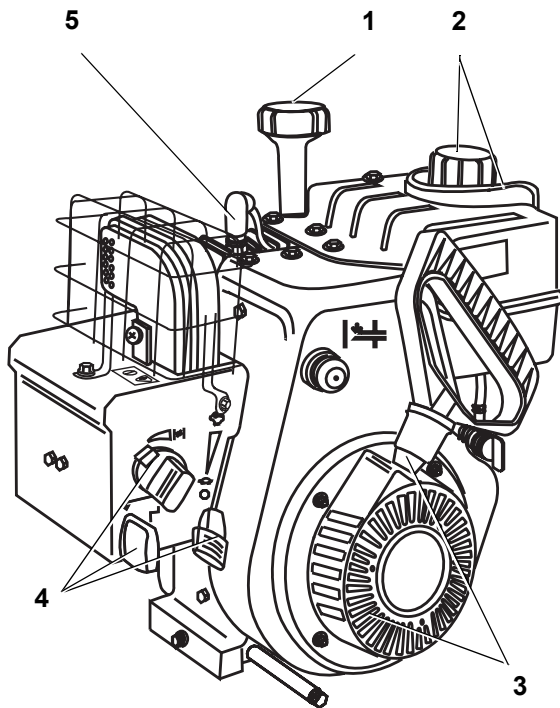

LH195SA/LH195SP

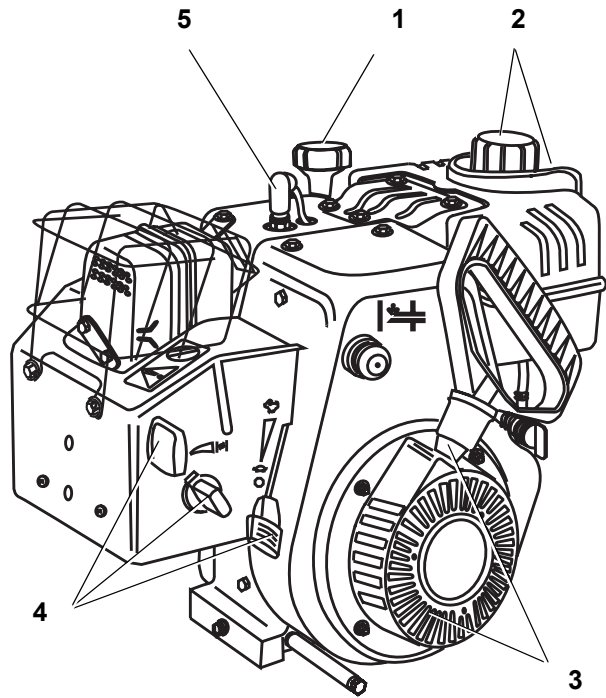

LH318SA/LH358SA

- 1. Oil Fill Cap/Dipstick
- 2. Fuel Fill Cap Areas
- 3. Recoil Starter/Flywheel Guard Areas
- 4. Linkage Areas
- 5. Spark Plug Connection

Figure 52. Snow and Debris Removal Locations

IX. Storing Your Engine

A. Short-Term/Seasonal Storage

I. Clean Engine

Before servicing the engine remove the carburetor cover and/or blower housing. Discard dirt and debris from the following areas:

- Cooling Fins
- Air Intake Screen or Recoil Starter/Flywheel Guard Areas
- Oil Fill Cap/Dipstick
- Fuel Fill Cap Areas
- Spark Plug Connection
- Levers
- Linkage Area
- Guards
- Carburetor
- Head

Removing debris will insure adequate cooling, correct engine speed and reduce the risk of fire.

II. Fuel Storage

⚠WARNING

NEVER store engine with fuel in fuel tank inside a building with potential sources of ignition such as hot water and space heaters, clothes dryers, electric motors, etc. Failure to do so may result in an explosion and result in death or serious injury.

NOTES

If engine fuel stored in the gas tank and/or an approved gas container is to be unused without gasoline stabilizer for more than 15-30 days, prepare it for short-term/seasonal storage. See "IV. Fuel Treatment" instructions. Afterward, continue reading instructions below.

*If engine fuel is to be stored for more than one season, without gasoline stabilizer, it will gradually deteriorate. Also, if it is stored in the engine's gas tank without gasoline stabilizer it is likely that your carburetor will have gum deposits, a clogged fuel system and **WILL VOID YOUR WARRANTY**. Prepare the fuel for extended storage. See "B. Extended Storage" instructions. Afterward, continue reading instructions.*

III. Fuel System

To avoid stale gas and carburetor problems, treat the fuel system in the following method below:

NOTES

*Tecumseh recommends using **ULTRA-FRESH™** Gasoline Stabilizer as an acceptable method of minimizing formation of fuel gum deposits during storage. This product is available from your Authorized Tecumseh Servicing Dealer.*

Always follow mix ratio found on stabilizer container. Failure to do so may result in equipment damage.

It is NOT necessary to empty stabilized gas from fuel tank.

IV. Fuel Treatment

1. Add fuel stabilizer according to manufacturer's instructions.
2. Run engine at least 10 minutes after adding stabilizer to allow it to reach carburetor.

⚠WARNING

NEVER store the engine with fuel in the fuel tank inside a building with potential sources of ignition such as hot water and space heaters, clothes dryers, electric motors, etc.

NOTE

Instead of using a fuel preservative/stabilizer, you can empty the fuel tank as described under "I. Draining Fuel" instructions. See "B. Extended Storage" instructions.

B. Extended Storage

I. Draining Fuel

NOTES

Clean debris from engine before emptying fuel from fuel tank. See "I. Clean Engine" instructions. Afterward, continue reading instructions below.

If you have prepared your fuel for short-term storage it is NOT necessary to empty fuel that contains stabilizer from your fuel tank. See "A. Short-Term/Seasonal Storage" instructions. Afterward, continue reading instructions below.

⚠WARNING

To avoid severe injury or death, DO NOT pour fuel from engine or siphon fuel by mouth.

1. To prevent serious injury from fuel fires, empty fuel tank by running engine until it stops from lack of fuel. DO NOT attempt to pour fuel from engine.
2. Run the engine while waiting until the remaining fuel is consumed.

⚠WARNING

NEVER leave the engine unattended when it is running and NEVER run engine in enclosed areas.

3. Begin servicing the cylinder bore. See "II. Oil Cylinder Bore" instructions on page 25.

II. Oil Cylinder Bore

⚠️ WARNING

When lubricating cylinder bore, fuel may spray from spark plug hole. To prevent serious injury from fuel fires, follow these instructions:

1. Carefully disconnect spark plug wire and keep it away from spark plug. See Figures 53 and 54.
 - Keep the disconnected spark plug wire securely away from metal parts where arcing could occur.
 - Carefully attach the spark plug wire to the grounding post, if provided.
 - Disconnect battery at negative terminal first, if engine is equipped with a D.C. electric starter.
 - Turn all engine switches to "OFF" position.
 - Remove ignition key, if provided.
2. Remove spark plug.
3. Squirt 1oz. (30ml) of clean engine oil into spark plug hole.
4. Cover spark plug hole with rag to prevent fuel from spraying from spark plug hole when starter rope is pulled.

NOTES

For engines equipped with recoil starters proceed to Step 5.

For engines equipped with electric starters proceed to Step 6.

5. Grasp starter cord handle:
 - a. Pull starter cord handle out *slowly* using a full arm stroke.
 - b. Repeat once. (This will distribute oil throughout the cylinder to prevent corrosion during storage.)
 - c. Proceed to Step 7.
6. Push starter button or turn ignition switch key to "START" position. Immediately release starter button or turn ignition switch key to "OFF" position. (This will distribute oil throughout the cylinder to prevent corrosion during storage.)
7. Remove rag from spark plug hole.
8. Install spark plug.
9. Carefully disconnect spark plug wire from grounding post, if provided. See Figure 53.
10. Connect spark plug wire plug wire to spark plug. See Figure 54.

III. Oil

Change oil if NOT changed within the last 3 months. See "B. Changing Oil" instructions on page 17.

IV. Battery

See equipment manufacturer's instructions for proper battery storage, if present.

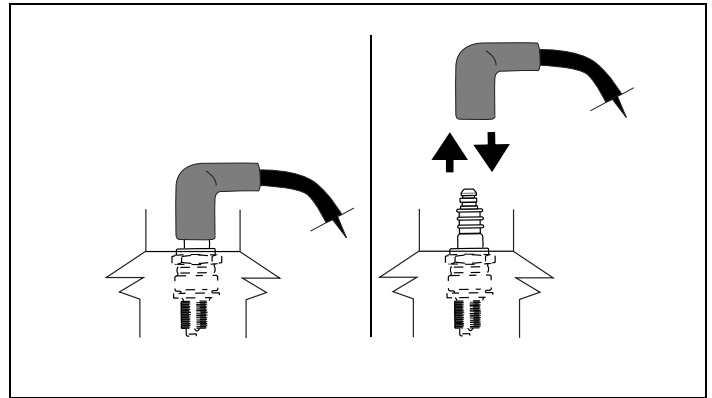

Figure 53. Disconnecting/Connecting Spark Plug

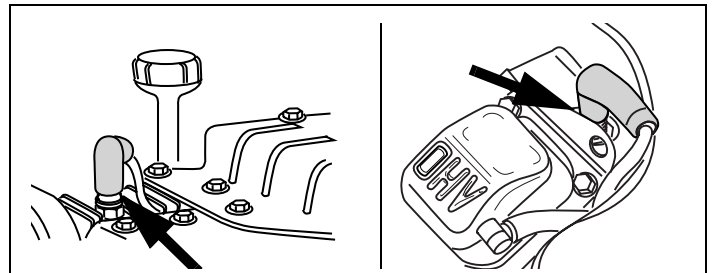

Figure 54. Typical Spark Plug Connection

X. Preventing Forest, Brush and Grass Fires

Local, state and federal laws may require use of a spark arrester to prevent fires. For example, it is a violation of California Public Resources Code (section 4442) to use or operate engine on any forest-covered, brush-covered or unimproved grass-covered land unless engine is equipped with a spark arrester. Spark arrester must be maintained in effective working order by owner and/or operator.

To determine if your engine has a spark arrester, locate the muffler on your engine. For example, the muffler discharge will have a spark arrester cover that reads "Tecumseh Screen Type 36085".

If your engine does NOT have a spark arrester, you may purchase one from your Authorized Tecumseh Servicing Dealer. In some cases the muffler may need to be replaced to allow the spark arrester to be installed.

XI. Maintenance Intervals

Maintenance is one of the most important things that you can do to extend the life of your Tecumseh Engine. If you are unable to perform maintenance intervals yourself, consult your local Authorized Tecumseh Servicing Dealer, call 1-800-558-5402, or go to www.TecumsehPower.com for additional information.

ALWAYS promptly follow maintenance intervals listed in this manual. See Table 4.

Table 4. Maintenance Intervals

Procedure	Time
Change Oil	After First 2 hrs. When Engine is Warm
Check Oil Level	5 hrs. Or Before Each Use
Clean Cooling Fins	5 hrs. Or Before Each Use
Change Oil	25 hrs. Or 3 mos.
Check Spark Plug	100 hrs. Or Seasonally
Replace Spark Plug	200 hrs. Or Seasonally

First Scheduled Maintenance

After First 2 Hours When Engine is Warm

1. Change Oil

Date _____ Owner/Dealer

CALIFORNIA & US EPA EMISSION CONTROL WARRANTY STATEMENT

The U. S. Environmental Protection Agency ("EPA"), the California Air Resources Board ("CARB") and Tecumseh Power Company are pleased to explain the Federal and California Emission Control Systems Warranty on your new small off-road engine. In California, new 1995 and later small off-road engines must be designed, built and equipped to meet the State's stringent anti-smog standards. In other states, new 1997 and later model year engines must be designed, built and equipped, at the time of sale, to meet the U.S. EPA regulations for small non-road engines. Tecumseh Power Company will warrant the emission control system on your small off-road engine for the periods of time listed below, provided there has been no abuse, neglect, unapproved modification, or improper maintenance of your small off-road engine.

Your emission control system may include parts such as the carburetor, air cleaner assembly, ignition system, exhaust system, crankcase breather assembly and, the evaporative control system. Also included may be the compression release system and other emission-related assemblies.

Where a warrantable condition exists, Tecumseh Power Company will repair your small off-road engine at no cost to you for diagnosis, parts and labor.

MANUFACTURER'S EMISSION CONTROL SYSTEM WARRANTY COVERAGE

Emission control systems on 1995 and later model year California small off-road engines are warranted for two years as hereinafter noted. In other states, 1997 and later model year engines are also warranted for two years. If, during such warranty period, any emission-related part on your engine is defective in materials or workmanship, the part will be repaired or replaced by Tecumseh Power Company

OWNER'S WARRANTY RESPONSIBILITIES

As the small off-road engine owner, you are responsible for the performance of the required maintenance listed in your Operator's Manual, but Tecumseh Power Company will not deny warranty solely due to the lack of receipts or for your failure to provide written evidence of the performance of all scheduled maintenance.

As the small off-road engine owner, you should, however, be aware that Tecumseh Power Company may deny you warranty coverage if your small off-road engine or a part thereof has failed due to abuse, neglect, improper maintenance or unapproved modifications.

You are responsible for presenting your small off-road engine to a Tecumseh Authorized Service Outlet (any Tecumseh Registered Service Dealer, Tecumseh Authorized Service Distributor or Tecumseh Central Warehouse Distributor) as soon as a problem exists. The warranty repairs should be completed in a reasonable amount of time, not to exceed 30 days.

Warranty service can be arranged by contacting either an Authorized Tecumseh Servicing Dealer and/or Tecumseh Power Company, c/o Service Manager, 900 North Street, Grafton, WI 53024-1499. Telephone 1-262-377-2700 [or in USA/Canada call 1-800-558-5402].

IMPORTANT NOTE

This warranty statement explains your rights and obligations under the Emission Control System Warranty ("ECS Warranty") which is provided to you by Tecumseh Power Company pursuant to California law. Tecumseh Power Company also provides to original purchasers of new Tecumseh Power Company engines the Tecumseh Power Company Limited Warranties for New Tecumseh Engines and Electronic Ignition Modules. The Tecumseh Power Company Limited Warranties for New Tecumseh Engines and Electronic Ignition Modules ("Tecumseh Power Company Warranty") are located on the back cover of the Operator's Manual, enclosed with all new Tecumseh Power Company engines. The ECS Warranty applies only to the emission control system of your new engine. To the extent that there is any conflict in terms between the ECS Warranty and the Tecumseh Power Company Warranty, the ECS Warranty shall apply except in any circumstances in which the Tecumseh Power Company Warranty may provide a longer warranty period. Both the ECS Warranty and the Tecumseh Power Company Warranty describe important rights and obligations with respect to your new engine.

Warranty service can only be performed by a Tecumseh Power Company Authorized Servicing Dealer. At the time of requesting warranty service, evidence must be presented of the date of sale to the original purchaser. The purchaser shall pay any charges for making service calls and/or for transporting the products to and from the place where the inspection and/or warranty work is performed. The purchaser shall be responsible for any damage or loss incurred in connection with the transportation of any engine or any part(s) thereof submitted for inspection and/or warranty work.

If you have any questions regarding your warranty rights and responsibilities, you should contact Tecumseh Power Company at 1-262-377-2700 or in USA/Canada call 1-800-558-5402.

Revised July, 2005

IMPORTANT!

The emission Regulations may be different for your country. The emissions Control Warranty Statement is only applicable to engines with an emissions compliance statement and decal that references "Emissions Regulations".

EMISSION CONTROL SYSTEM WARRANTY

Emission Control System Warranty ("ECS Warranty") for 1995 and later model year California small off-road engines (for other states, 1997 and later model year engines):

A. APPLICABILITY: This warranty shall apply to 1995 and later model year California small off-road engines (for other states, 1997 and later model year engines). The ECS Warranty Period shall begin on the date the new engine or equipment is delivered to its original, end-use purchaser, and shall continue for 24 consecutive months thereafter.

B. GENERAL EMISSIONS WARRANTY COVERAGE:

Tecumseh Power Company warrants to the original, end-use purchaser of the new engine or equipment and to each subsequent purchaser that each of its small off-road engines is:

1. Designed, built and equipped so as to conform with all applicable regulations adopted by the Air Resources Board pursuant to its authority in Chapters 1 and 2, Part 5, Division 26 of the Health and Safety Code, and
2. Free from defects in materials and workmanship which, at any time during the ECS Warranty Period, will cause a warranted emissions-related part to fail to be identical in all material respects to the part as described in the engine manufacturer's application for certification.

C. THE ECS WARRANTY ONLY PERTAINS TO EMISSION-RELATED PARTS ON YOUR ENGINE AS FOLLOWS:

1. Any warranted, emissions-related parts which are not scheduled for replacement as required maintenance in the Operator's Manual shall be warranted for the ECS Warranty Period. If any such part fails during the ECS Warranty Period, it shall be repaired or replaced by Tecumseh Power Company according to Subsection 4 below. Any such part repaired or replaced under the ECS Warranty shall be warranted for any remainder of the ECS Warranty Period.
2. Any warranted, emissions-related part which is scheduled only for regular inspection as specified in the Operator's Manual shall be warranted for the ECS Warranty Period. A statement in such written instructions to the effect of "repair or replace as necessary", shall not reduce the ECS Warranty Period. Any such part repaired or replaced under the ECS Warranty shall be warranted for the remainder of the ECS Warranty Period.
3. Any warranted, emissions-related part which is scheduled for replacement as required maintenance in the Operator's Manual, shall be warranted for the period of time prior to the first scheduled replacement point for that part. If the part fails prior to the first scheduled replacement, the part shall be repaired or replaced by Tecumseh Power Company according to Subsection 4 below. Any such emissions-related part repaired or replaced under the ECS Warranty, shall be warranted for the remainder of the ECS Warranty Period prior to the first scheduled replacement point for such emissions-related part.
4. Repair or replacement of any warranted, emissions-related part under this ECS Warranty shall be performed at no charge to the owner at a Tecumseh Authorized Service Outlet.

5. The owner shall not be charged for diagnostic labor which leads to the determination that a part covered by the ECS Warranty is in fact defective, provided that such diagnostic work is performed at a Tecumseh Authorized Service Outlet.
6. Tecumseh Power Company shall be liable for damages to other original engine components or approved modifications proximately caused by a failure under warranty of an emission-related part covered by the ECS Warranty.
7. Throughout the ECS Warranty Period, Tecumseh Power Company shall maintain a supply of warranted emission-related parts sufficient to meet the expected demand for such emission-related parts.
8. Any Tecumseh Power Company authorized and approved emission-related replacement part may be used in the performance of any ECS Warranty maintenance or repair and will be provided without charge to the owner. Such use shall not reduce Tecumseh Power Company ECS Warranty obligations.
9. Unapproved add-on or modified parts may not be used to modify or repair a Tecumseh Power Company engine. Such use voids this ECS Warranty and shall be sufficient grounds for disallowing an ECS Warranty claim. Tecumseh Power Company shall not be liable hereunder for failures of any warranted parts of a Tecumseh Power Company engine caused by the use of such an unapproved add-on or modified part.

EMISSION-RELATED PARTS INCLUDE THE FOLLOWING:

1. Carburetor Assembly including internal components:
 - a) Carburetor gaskets
 - b) Intake pipe
2. Air Cleaner Assembly including components:
 - a) Air filter element
3. Ignition System including components:
 - a) Spark plug
 - b) Ignition module
 - c) Flywheel assembly
4. Exhaust System including components:
 - a) Catalytic muffler (*if so equipped*)
 - b) Muffler gasket (*if so equipped*)
 - c) Exhaust manifold (*if so equipped*)
5. Crankcase Breather Assembly including components
 - a) Breather connection tube
6. Evaporative Control System including components:
 - a) Fuel line(s)
 - b) Fuel filter
 - c) Canister (*if so equipped*)
 - d) Fuel tank (*if so equipped*)
 - e) Fuel fill cap (*if so equipped*)

Revised July, 2005

IMPORTANT!

The emission Regulations may be different for your country. The emissions Control Warranty Statement is only applicable to engines with an emissions compliance statement and decal that references "Emissions Regulations".

XII. Warranty Information

LIMITED WARRANTY FOR NEW TECUMSEH ENGINES AND ELECTRONIC IGNITION MODULES

For the time period shown below from the date of purchase and subject to the exceptions and limitations described herein, Tecumseh Power Company will, at its option as the exclusive remedy, either repair or replace for the original purchaser, free of charge, any part of any new Tecumseh engine which is found, upon examination by any Authorized Tecumseh Servicing Outlet or by Tecumseh's factory in Grafton, Wisconsin, to be **DEFECTIVE IN MATERIAL AND/OR WORKMANSHIP**. This Limited Warranty **DOES NOT COVER** (i) any Tecumseh engine or part(s) thereof used to power any vehicle in competitive racing and/or used on any commercial or rental track, or (ii) defects or damage caused by alterations or modifications of new Tecumseh engines or parts or by normal wear, accidents, improper maintenance, improper use or abuse of the product, or failure to follow the instructions contained in an Instruction Manual for the operation of the new Tecumseh engine or part. The cost of normal maintenance or replacement of service items which are not defective shall be paid for by the original purchaser. At the time warranty service is requested, evidence must be presented of the date of purchase by the original purchaser. Any charge for making service calls and/or for transporting any engine or part(s) thereof to and from the place where the inspection and/or warranty work is performed is payable solely by the purchaser. The purchaser is responsible for any damage or loss incurred in connection with the transportation of any engine or part(s) thereof submitted for inspection and/or warranty work. **WARRANTY SERVICE CAN ONLY BE PERFORMED BY A TECUMSEH AUTHORIZED SERVICE OUTLET.** Warranty service can be arranged by contacting a Tecumseh Authorized Service Outlet (any Tecumseh Registered Service Dealer, Tecumseh Authorized Service Distributor, or Tecumseh Central Warehouse Distributor) or by contacting Tecumseh c/o Service Manager, 900 North Street, Grafton, Wisconsin 53024-1499.

Warranty	"CONSUMER USE" (4)		"COMMERCIAL USE" (5)	
	Within	Outside	Within	Outside
Category	U.S.A. and Canada	U.S.A. and Canada	U.S.A. and Canada	U.S.A. and Canada
(A)	90 Day	90 Day ⁽¹⁾	No Warranty	No Warranty
(B)	1 Year	1 Year ⁽¹⁾	1 Year	1 Year
(C)	2 Years	1 Year ⁽¹⁾	1 Year	1 Year
(D)	2 Years	2 Years ⁽²⁾	1 Year	1 Year
(E)	2 Years	2 Years	1 Year	1 Year
(H)	2 'n 10 ⁽³⁾	2 'n 10 ⁽³⁾	1 Year	1 Year
(K)	2 'n 10 ⁽³⁾	2 'n 10 ⁽³⁾	2 'n 10 ⁽³⁾	1 Year
(M) ⁽⁷⁾	3 Years	3 Years	1 Year	1 Year

- (1) 2 years for Member States of the European Union. Consumers may have additional legal rights not affected by the terms of this warranty pursuant to EU Directive 1999/44/EC and the national legislation of certain Member States of the European Union.
- (2) 1 year for Australian/New Zealand for rotary mower engines.
- (3) 2 years on engine and 10 years (the first 5 years covering parts and labor only; the second 5 years covering parts only) on electronic ignition.
- (4) For purposes of this warranty policy, "consumer use" shall mean consumer's personal, residential, household use by the original retail purchaser.
- (5) For purposes of this warranty policy, "commercial use" shall mean all other uses, including use for commercial, income producing, or rental purposes.
- (6) The engine warranty category of your engine can be determined by review of the engine model number on the "Important Engine Information" decal. One letter in the engine model number will be surrounded by parenthesis (A), (B), (C), (D), (E), (H) (K) or (M) and that letter is your engine warranty category designation.
- (7) Qualification for three (3) year consumer use warranty under engine warranty category (M) may be determined by notation of an (M) designation on the "Important Engine Information" decal located on the engine housing or an addendum decal affixed adjacent thereto.

THIS EXPRESS WARRANTY IS SUPPLEMENTED BY THE TECUMSEH CALIFORNIA EMISSION CONTROL WARRANTY STATEMENT, if any.

THIS EXPRESS WARRANTY IS IN LIEU OF ALL OTHER EXPRESS WARRANTIES. Neither Tecumseh nor any of its affiliates makes any warranties, representations, or promises, written or oral, as to the quality of the engine or any of its parts, other than as set forth herein. **ANY IMPLIED WARRANTY OF MARKETABILITY, MERCHANTABILITY, OR FITNESS FOR A PARTICULAR PURPOSE, TO THE EXTENT THAT EITHER MAY APPLY TO ANY TECUMSEH ENGINE OR PART(S) THEREOF, SHALL BE LIMITED IN DURATION TO THE PERIODS OF THE EXPRESS WARRANTIES SHOWN IN THE WARRANTY PERIOD CHART ABOVE AND TO THE EXTENT PERMITTED BY LAW ANY AND ALL IMPLIED WARRANTIES ARE EXCLUDED. IN NO EVENT WILL TECUMSEH BE LIABLE FOR ANY INDIRECT, INCIDENTAL, CONSEQUENTIAL OR SPECIAL DAMAGES AND/OR EXPENSES, INCLUDING, BUT NOT LIMITED TO, ANY LOSS OF TIME, INCONVENIENCE, LOSS OF UNIT USE OR ANY COST OR EXPENSE OF SUBSTITUTE UNITS DURING PERIODS OF MALFUNCTION OR NON-USE.** Some states do not allow limitations on how long an implied warranty lasts or the exclusion or limitation of incidental or consequential damages, so the above limitation(s) or exclusion(s) may not apply to you. This Limited Warranty gives you specific legal rights and you may also have other legal rights which vary from state-to-state.

Tecumseh neither assumes nor authorizes any other person, natural or corporate, to assume for Tecumseh any other obligations or liabilities in connection with or with respect to any Tecumseh product or parts. The seller or dealer of a Tecumseh Product or part has no authority, whatsoever, to make any representations or promises on behalf of Tecumseh or to modify the terms or limitations of Tecumseh's warranty in any way.

Revised January, 2004

WARNING CALIFORNIA PROPOSITION 65

The engine exhaust from this product contains chemicals known to the State of California to cause cancer, birth defects or other reproductive harm.

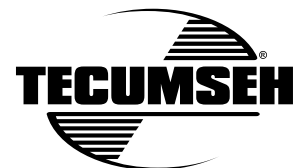

Tecumseh Power Company • Grafton, Wisconsin 53024-1499 • USA

Telephone: 1-800-558-5402

Visit us at: www.TecumsehPower.com

181-1275-14
(English) 01/01/07