

Operator's Manual

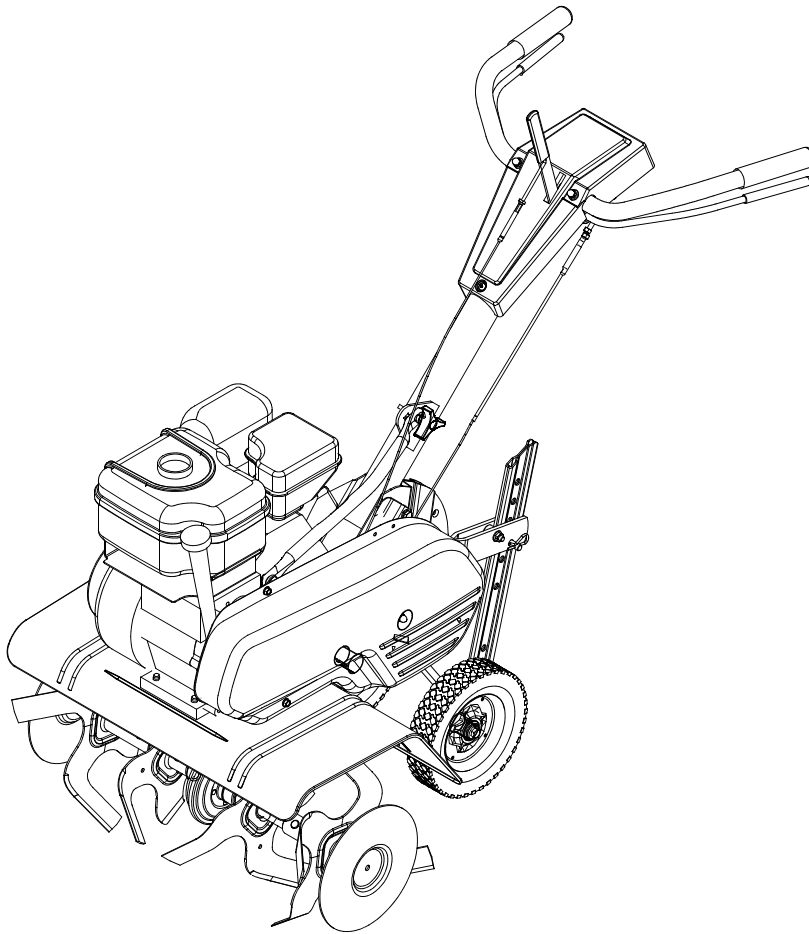

Model Series 390 Shown

Front Tine Tillers

**Model Series
340 Thru 390**

IMPORTANT: READ SAFETY RULES AND INSTRUCTIONS CAREFULLY

Warning: This unit is equipped with an internal combustion engine and should not be used on or near any unimproved forest-covered, brush-covered or grass-covered land unless the engine's exhaust system is equipped with a spark arrester meeting applicable local or state laws (if any). If a spark arrester is used, it should be maintained in effective working order by the operator. In the State of California the above is required by law (Section 4442 of the California Public Resources Code). Other states may have similar laws. Federal laws apply on federal lands. A spark arrester for the muffler is available through your nearest engine authorized service dealer or contact the service department, P.O. Box 361131 Cleveland, Ohio 44136-0019.

MTD LLC, P.O. BOX 361131 CLEVELAND, OHIO 44136-0019

PRINTED IN U.S.A.

FORM NO. 770-10135C
(11/03)

TABLE OF CONTENTS

Content	Page	Content	Page
Important Safe Operation Practices	3	Maintaining Your Tiller	11
Assembling Your Tiller	5	Troubleshooting	14
Know Your Tiller	7	Illustrated Parts List	16
Operating Your Tiller	8	Warranty	24
Making Adjustments	11		

FINDING MODEL NUMBER

This Operator's Manual is an important part of your new tiller. It will help you assemble, prepare and maintain the unit for best performance. Please read and understand what it says.



Before you start assembling your new equipment, please locate the model plate on the equipment and copy the information from it in the space provided below. A sample model plate is also given below. You can locate the model plate by standing at the operating position and looking down at the right side of the frame. This information will be necessary to use the manufacturer's web site and/or help from the Customer Support Department or an authorized service dealer.



Copy the model number here: _____

Copy the serial number here: _____

CUSTOMER SUPPORT

Please do NOT return the unit to the retailer from where it was purchased, without first contacting Customer Support.

If you have difficulty assembling this product or have any questions regarding the controls, operation or maintenance of this unit, you can seek help from the experts. Choose from the options below:

	<p>Visit mtdproducts.com for many useful suggestions. Click on Customer Support button and you will get the four options reproduced here. Click on the appropriate button and help is immediately available.</p> <div style="text-align: center; border: 1px solid black; padding: 5px; margin: 10px auto; width: 80%;"> <p>Find Answers Click here to search our knowledge base. Search by product, keyword, or phrase.</p> <hr/> <p>My Stuff Login to check the status of your questions, modify your inquiries, or update your personal profile.</p> <hr/> <p>Service Locator Need local assistance? Click here to find authorized service centers in your area.</p> <hr/> <p>Manuals Online Need a manual and/or parts list? Download literature from recent model years.</p> </div> <p style="text-align: center;"><i>The answer you are looking for could be just a mouse click away!</i></p>	<p><i>The answer you are looking for could be just a mouse click away!</i></p>
	<p>If you prefer to reach a Customer Support Representative, please call 1-800-800-7310.</p>	
	<p>The engine manufacturer is responsible for all engine-related issues with regards to performance, power-rating, specifications, warranty and service. Please refer to the engine manufacturer's Owner's/Operator's Manual, packed separately with your unit, for more information.</p>	

SECTION 1: IMPORTANT SAFE OPERATION PRACTICES



WARNING: This symbol points out important safety instructions which, if not followed, could endanger the personal safety and/or property of yourself and others. Read and follow all instructions in this manual before attempting to operate this machine. Failure to comply with these instructions may result in personal injury. When you see this symbol— heed its warning.



WARNING: Engine exhaust, some of its constituents, and certain vehicle components contain or emit chemicals known to State of California to cause cancer and birth defects or other reproductive harm.

DANGER: This machine was built to be operated according to the rules for safe operation in this manual. As with any type of power equipment, carelessness or error on the part of the operator can result in serious injury. This machine is capable of amputating hands and feet. Failure to observe the following safety instructions could result in serious injury or death.

Training

1. Read, understand, and follow all instructions on the machine and in the manual(s) before attempting to assemble and operate. Keep this manual in a safe place for future and regular reference and for ordering replacement parts.
2. Be familiar with all controls and their proper operation. Know how to stop the machine and disengage them quickly.
3. Never allow children under 14 years old to operate this machine. Children 14 years old and over should read and understand the operation instructions and safety rules in this manual and should be trained and supervised by a parent.
4. Never allow adults to operate this machine without proper instruction.
5. Keep bystanders, helpers, pets and children at least 75 feet from the machine while it is in operation. Stop machine if anyone enters the area.
7. Use only an approved gasoline container.
8. Extinguish all cigarettes, cigars, pipes and other sources of ignition.
9. Never fuel machine indoors.
10. Never remove gas cap or add fuel while the engine is hot or running.
11. Allow engine to cool at least two minutes before refueling.
12. Never over fill fuel tank. Fill tank to no more than ½ inch below bottom of filler neck to provide space for fuel expansion.
13. Replace gasoline cap and tighten securely.
14. If gasoline is spilled, wipe it off the engine and equipment. Move machine to another area. Wait 5 minutes before starting the engine.
15. Never store the machine or fuel container inside near an open flame, spark or pilot light (e.g. furnace, water or space heater, clothes dryer etc.).
16. Allow machine to cool 5 minutes before storing.

Preparation

1. Thoroughly inspect the area where the equipment is to be used. Remove all stones, sticks, wire, and other foreign objects which could be tripped over and cause personal injury.
2. Wear sturdy, rough-soled work shoes and close fitting slacks and shirt. Loose fitting clothes or jewelry can be caught in movable parts. Never operate this machine in bare feet or sandals.
3. Disengage clutch levers and shift (if provided) into neutral (“N”) before starting the engine.
4. Never leave this machine unattended with the engine running.
5. Never attempt to make any adjustments while engine is running, except where specifically recommended in the operator’s manual.
6. To avoid personal injury or property damage use extreme care in handling gasoline. Gasoline is extremely flammable and the vapors are explosive. Serious personal injury can occur when gasoline is spilled on yourself or your clothes which can ignite. Wash your skin and change clothes immediately.

Operation

1. Do not put hands or feet near rotating parts. Contact with the rotating parts can amputate hands and feet.
2. Do not operate machine while under the influence of alcohol or drugs.
3. Never operate this machine without good visibility or light. Always be sure of your footing and keep a firm hold on the handles.
4. Keep bystanders, helpers, pets, and children at least 75 feet from the machine while it is in operation. Stop the machine if anyone enters the area.
5. Be careful when tilling in hard ground. The tines may catch in the ground and propel the tiller forward. If this occurs, let go of the handle bars and do not restrain the machine.
6. Exercise extreme caution when operating on or crossing gravel surfaces. Stay alert for hidden hazards or traffic. Do not carry passengers.
7. Never operate the machine at high transport speeds on hard or slippery surfaces.
8. Exercise caution to avoid slipping or falling.

9. Look down and behind and use care when in reverse or pulling machine towards you.
10. Start the engine according to the instructions found in this manual and keep feet well away from the tines at all times.
11. After striking a foreign object, stop the engine, disconnect the spark plug wire and ground against the engine. Thoroughly inspect the machine for any damage. Repair the damage before starting and operating.
12. Disengage all clutch levers and stop engine before you leave the operating position (behind the handles). Wait until the tines come to a complete stop before unclogging the tines, making any adjustments, or inspections.
13. Never run an engine indoors or in a poorly ventilated area. Engine exhaust contains carbon monoxide, an odorless and deadly gas.
14. Muffler and engine become hot and can cause a burn. Do not touch.
15. Use caution when tilling near fences, buildings and underground utilities. Rotating tines can cause property damage or personal injury.
16. Do not overload machine capacity by attempting to till soil to deep at to fast of a rate.
17. If the machine should start making an unusual noise or vibration, stop the engine, disconnect the spark plug wire and ground it against the engine. Inspect thoroughly for damage. Repair any damage before starting and operating.
18. Keep all shields, guards and safety devices in place and operating properly.
19. Never pick up or carry machine while the engine is running.
20. Use only attachments and accessories approved by the manufacturer. Failure to do so, can result in personal injury.
21. If situations occur which are not covered in this manual, use care and good judgment. Contact your dealer or telephone 1-800-800-7310 for assistance and the name of your nearest servicing dealer.

Maintenance & Storage

1. Never tamper with safety devices. Check their proper operation regularly.
2. Check bolts and screws for proper tightness at frequent intervals to keep the machine in safe working condition. Also, visually inspect machine for any damage.
3. Before cleaning, repairing, or inspecting, stop the engine and make certain the tines and all moving parts have stopped. Disconnect the spark plug wire and ground it against the engine to prevent unintended starting.

4. Do not change the engine governor settings or over-speed the engine. The governor controls the maximum safe operating speed of the engine.
5. Maintain or replace safety and instruction labels, as necessary.
6. Follow this manual for safe loading, unloading, transporting, and storage of this machine.
7. Never store the machine or fuel container inside where there is an open flame, spark or pilot light such as a water heater, furnace, clothes dryer etc.
8. Always refer to the operator's manual for proper instructions on off-season storage.
9. If the fuel tank has to be drained, do this outdoors.
10. Observe proper disposal laws and regulations for gas, oil, etc. to protect the environment.

Your Responsibility

1. Restrict the use of this power machine to persons who read, understand and follow the warnings and instructions in this manual and on the machine.
2. The safety label on the tiller is reproduced below for your review. To ensure safe operation of the tiller, follow the instructions on all labels closely.

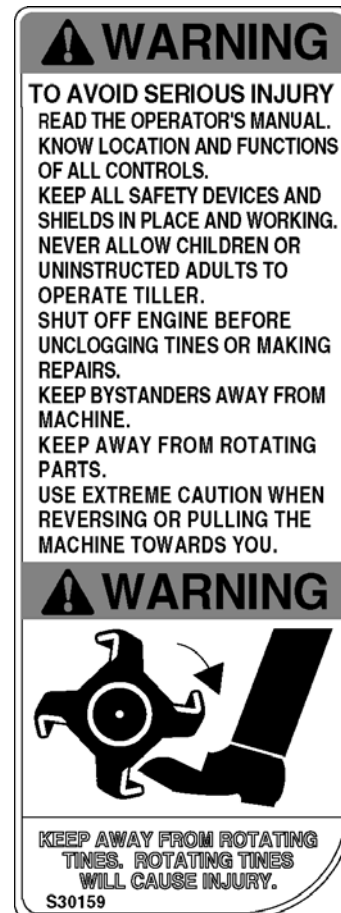

SECTION 2: ASSEMBLING YOUR TILLER

NOTE: This operator's guide covers three different model tillers. Model series 340 thru 345 have forward tine drive only. Model series 390 has both forward and reverse tine drive. Follow only the instructions which pertain to your model tiller. See the model plate on your tiller for the correct model number.

NOTE: References to right or left side of the tiller are determined from behind the unit in the operating position.

Removing Unit From Carton

- Remove staples, break glue on top flaps, or cut tape at carton end and peel along top flap to open carton.
- Remove all loose parts included with unit (i.e., operator's manual, etc.)
- Cut corners and lay carton down flat.
- Remove packing material.
- Roll or slide unit out of carton. Check carton thoroughly for loose parts.
- Extend control cable(s) to the rear of the tiller and lay them on the floor. Be careful not to bend or kink control cable(s).

IMPORTANT: This unit is shipped without gasoline or oil in the engine. Be certain to service engine with gasoline and oil as instructed in the separate engine manual before operating your machine.

Before Assembly



WARNING: Disconnect the spark plug wire and ground it against the engine to prevent unintended starting.

Attaching Tailpiece And Depth Stake

NOTE: If your tiller's tailpiece and depth stake has been already assembled before shipping, proceed to the next section. If it is unassembled, follow the steps below.

Remove the two self-tapping screws on the frame. Slide the tailpiece into the frame with the lower hole in the tailpiece toward the front. Secure with screws just removed. See Figure 1.

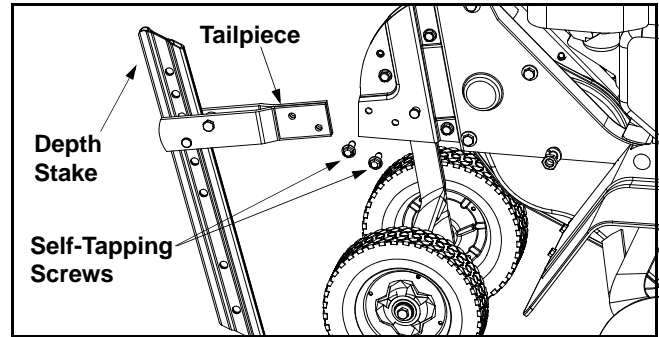

Figure 1

Attaching Handle Assembly

- Remove the hex bolt and cupped washer from the top right side of the frame halves. Hold the cable guide bracket on the left side of the frame as it will fall when the bolt is removed. See Figure 2.

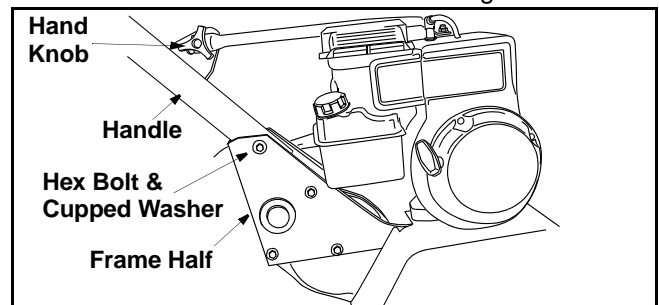

Figure 2

- Insert the handle assembly between the two frame halves. Insert the hex bolt just removed through the frame halves, handle assembly, and into the cable guide bracket (notch in cable guide bracket goes over the flange on the frame). Tighten securely.
- Loosen the hand knob which secures the handle brace to the handle assembly. **(Standard Briggs & Stratton & Tecumseh Engines).**
- Remove the hand knob from the handle brace. **(Honda and Briggs & Stratton Intek Engines).**
- Insert the carriage bolt through the welded bracket on the handle, bell washer, handle brace, and into the hand knob. Tighten securely. See Figure 3. **(Honda and Briggs & Stratton Intek Engines).**
- Remove the hex lock nut from on top of the engine, just to the left of the spark plug. Attach the curved end of the handle brace to the top of the engine, using hex lock nut just removed. Tighten securely. See Figure 3. **(Standard Briggs & Stratton & Tecumseh Engines).**
- Select one of the three handle height positions (three notches in welded bracket), and tighten the hand knob to secure the handle in desired position. Make certain carriage bolt is seated securely into one of the three positions provided.

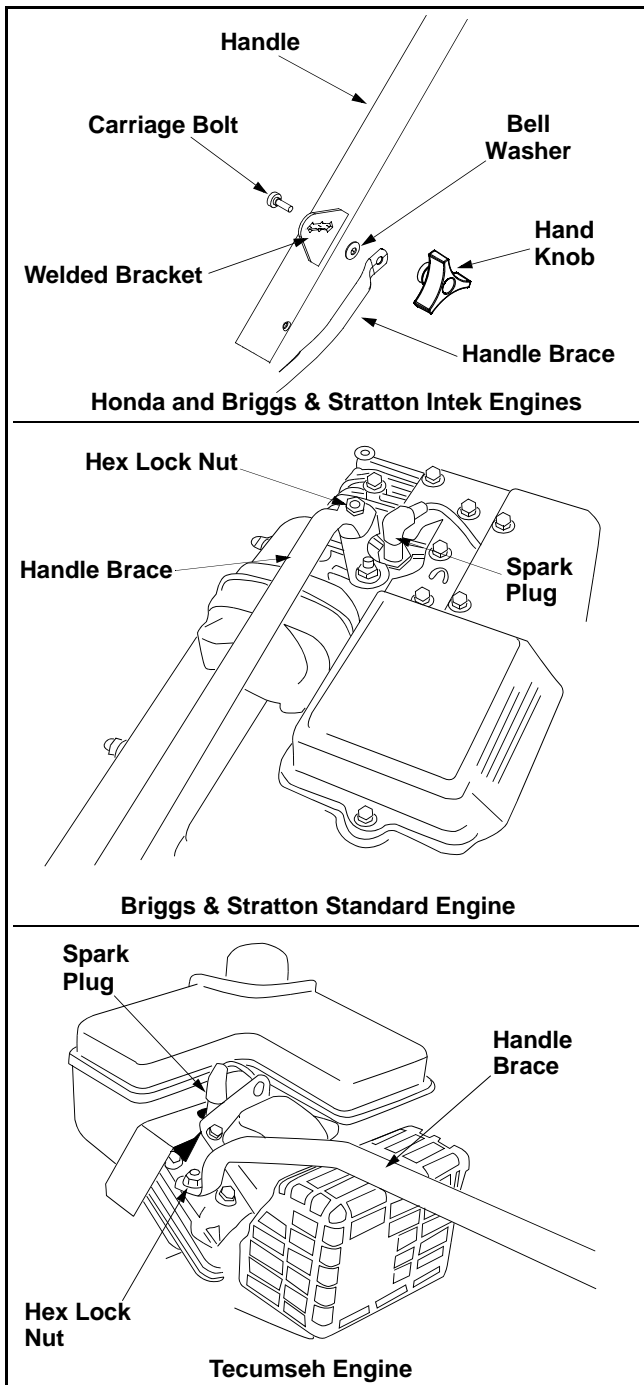

Figure 3

Attaching Clutch Control Cable(s)

NOTE: If your tiller's clutch control cable(s) have been already assembled before shipping, proceed to the next section. If unassembled, follow the steps below.

Forward Cable

Attach the end of the forward cable to the bracket underneath the handle assembly as follows. (On model series 390, the forward clutch cable is the cable which is attached closer to the rear of the tiller).

- Loosen the hex nut on the threaded rod near the end of the cable, and move it up the rod as far as it will go.
- Unthread the rod from the rest of the cable. Hook the "Z" end of the rod into the bracket underneath the handle assembly from the right hand side. See Figure 4.
- Thread the rod back into the cable until the cable is straight. Do not tighten it enough to put any tension on the spring.
- Thread the hex nut down against the end of cable. Use a pair of pliers and a wrench to lock the nut against the rod.

NOTE: Do not overtighten control cable. Too much tension may cause it to break when engaged.

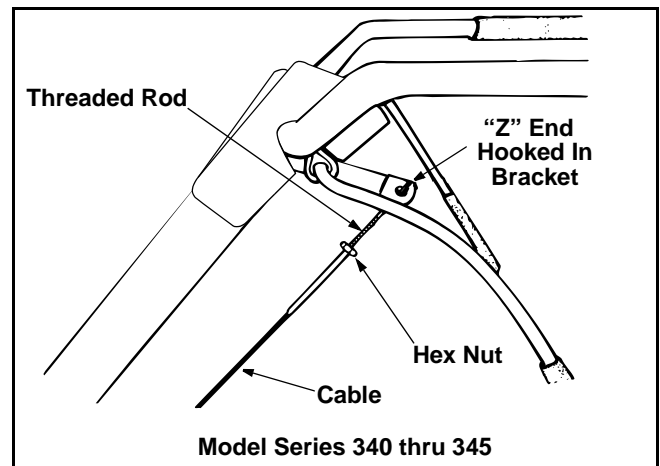

Figure 4

Reverse Cable (Model Series 390 Only)

The reverse clutch cable is the cable which is attached closer to the front of the tiller. Attach the end of the reverse cable to the reverse tine drive clutch lever, above the handle assembly, in the same manner as you attached the forward cable. See Figure 5.

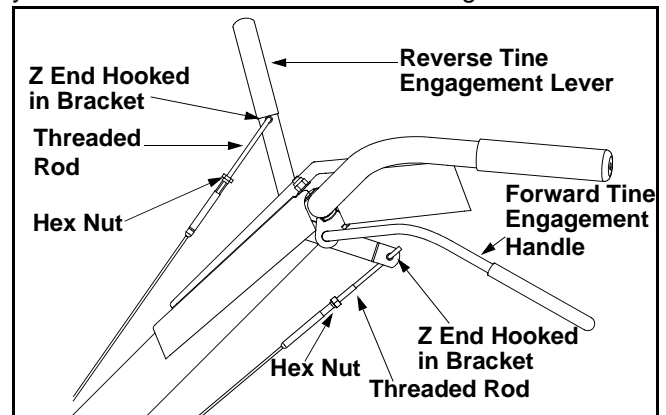

Figure 5

Final Clutch Adjustment

To check the clutch cable adjustment, proceed as follows:

- Disconnect the spark plug wire and move it away from the spark plug to prevent accidental starting.
- Engage and release the tine engagement handle, then the reverse tine engagement lever (model series 390 only). If an excessive noise is heard when releasing either the tine drive clutch handle or lever, the cable may be too loose. Adjust either the forward or reverse clutch cable by loosening the hex nut, threading the rod into the cable one or two turns, then retightening the nut.
- With tine engagement handle in neutral (released) as shown in Figure 6, pull the starter rope several times. **The tines should not turn.** If they turn forward, loosen the hex nut on the forward cable (underneath the handle assembly). If they turn toward the rear (model series 390 only), loosen the hex nut on the reverse cable (above the handle

assembly). Unthread the rod from the cable 2 or 3 turns. Retighten the hex nut, and check again for correct adjustment. See Figure 6.

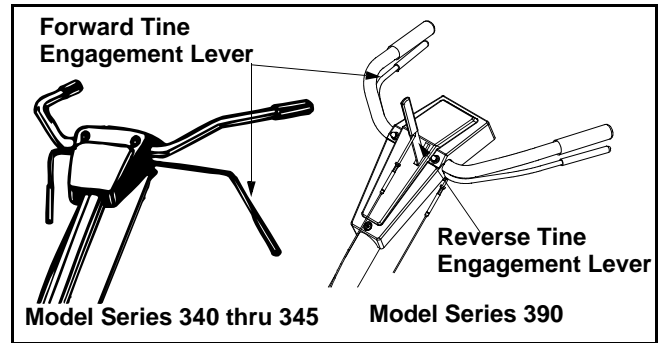

Figure 6

SECTION 3: KNOW YOUR TILLER



WARNING: Read, understand, and follow all instructions and warnings on the machine and in this manual before operating.

Throttle Control

The throttle control lever is located on the engine. It controls the engine speed and stops the engine. See Figure 7.

Choke Lever (Model Series 340/390)

The choke lever is located above the throttle control. It is used to enrich the fuel mixture when starting a cold engine. See Figure 7.

Primer Button (Model 345)

The primer button is located behind the air cleaner. It is used to enrich the fuel mixture in the carburetor when starting a cold engine. See Figure 7.

Forward Tine Engagement Handle

The forward tine engagement handle is located beneath the tiller handle. Squeezing the handle up against the tiller handle engages the tines. Release the handle to stop the tines. See Figure 8.

Reverse Tine Drive Clutch Lever

(Model Series 390 Only)

The reverse tine drive clutch lever is located on top of the handle panel. Pull the lever to the rear to move the tines in reverse. Release the lever to stop the reverse tine drive. See Figure 8.

NOTE: Never engage both the forward and reverse tine drives at the same time. Engaging both forward and reverse tine drives at the same time could damage the belt drives and cause the engine to stall.

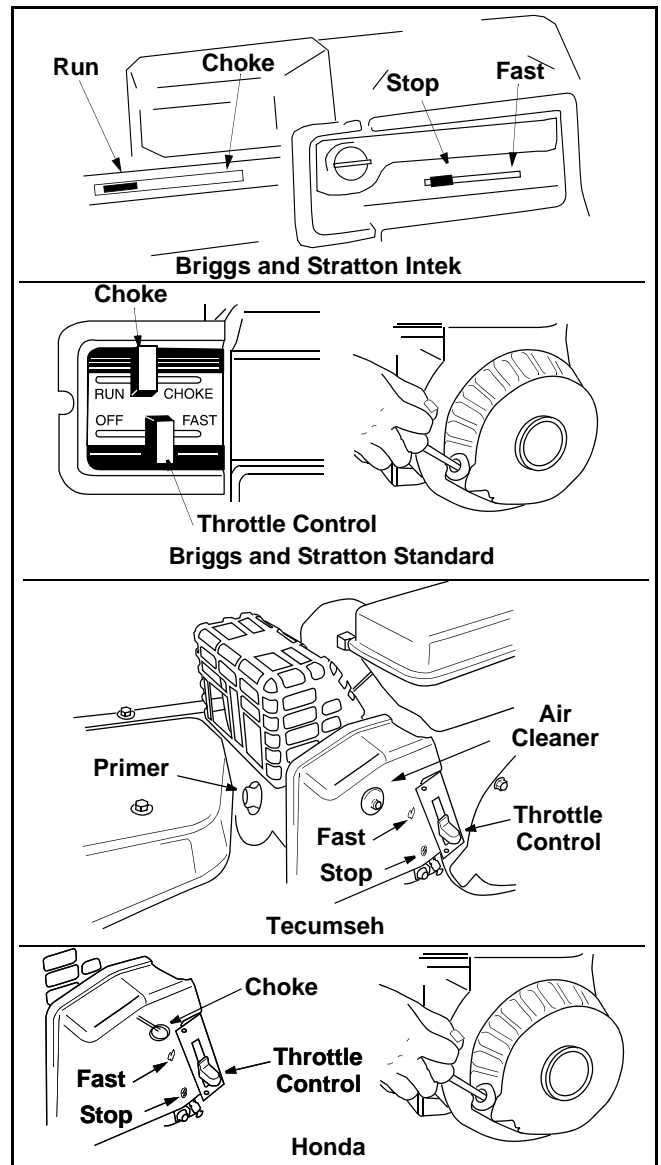

Figure 7

Depth Stake

The depth stake controls the tilling depth. Refer to OPERATING YOUR TILLER in Section 4.

Tines And End Caps

The tilling tines and end caps (are used to cultivate, furrow, and prepare your garden for seeding. The end caps (Model Series 390 only) are used to avoid tilled soil from overflowing onto unwanted areas.

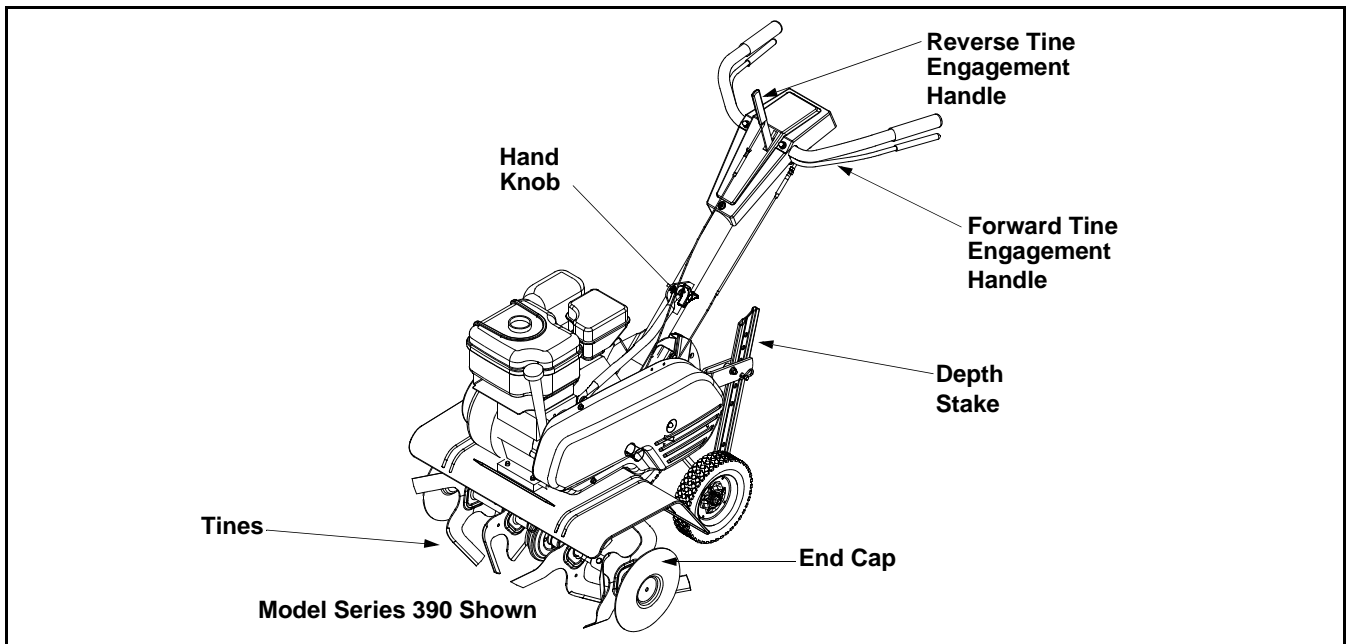

Figure 8

SECTION 4: OPERATING YOUR TILLER

Gas and Oil Fill up

Service the engine with gasoline and oil as instructed in the separate engine manual packed with your tiller.

Read instructions carefully.

Starting Engine



WARNING: Be sure no one is standing in front of the tiller while the engine is running or being started.

Models 340, 342, & 395

- Attach spark plug wire to spark plug. Make certain the metal loop on the end of the spark plug wire (inside the boot) is fastened securely over the metal tip on the spark plug.
- Make certain all controls are in the neutral position (released). See Figure 6.
- Place the throttle control lever in FAST position. See Figure 7.
- Move/pull out choke lever to CHOKE position. (A warm engine requires little or no choke.)
- Grasp starter handle and pull rope out slowly until engine reaches start of compression cycle (rope will pull slightly harder at this point). Let the rope rewind slowly.

- Pull rope with a rapid, continuous, full arm stroke. Keep a firm grip on starter handle. Let rope rewind slowly. Do not let starter handle snap back against starter.
- Repeat preceding instructions until engine starts. When engine starts, move/push in choke lever on engine halfway between CHOKE and RUN.
- Move throttle control to IDLE position for a few minutes warm-up. Move/push in choke lever to RUN position as engine warms up.

Models 343 & 345

- Attach spark plug wire to spark plug. Make certain the metal loop on the end of the spark plug wire (inside the boot) is fastened securely over the metal tip on the spark plug.
- Make certain all controls are in the neutral position (released). See Figure 8.
- Place the engine speed control in the START position.
- Push primer two (2) or three (3) times. Wait about two (2) seconds between each push.

NOTE: Primer may be needed to restart a warm engine after a short shutdown.

- Stand at side of tiller. Grasp the starter handle and pull out slowly, until it pulls slightly harder. Let rope rewind slowly.
- Pull rope with a rapid full arm stroke. Do not allow handle to snap back. Allow it to rewind slowly while keeping a firm hold on the starter handle.

NOTE: If engine fails to start after three (3) pulls, push primer two (2) times and pull starter rope again.

- Repeat previous steps until engine starts. Refer to engine manual for additional engine information.

To Stop Engine

- Move throttle control lever to STOP or OFF position.
- Disconnect spark plug wire from spark plug and ground against the engine to prevent accidental starting while equipment is unattended.

NOTE: See your engine manual packed with your unit for more detailed instructions.

Using Your Tiller

Your tiller is a precision built machine designed for seed bed preparation, cultivating, furrowing and mulching. It is engineered to minimize the hardest work in the vegetable or flower garden, to till the soil for planting and cultivating, and to perform many other useful labor saving tasks in the garden.

With the proper amount of care and maintenance, this machine will provide the owner with many years of service.

Wheel Position

The tiller is shipped with the wheels adjusted such that the unit sits level. While tilling, as the tines enter the ground and the front of the tiller lowers, the wheels must be raised to level the unit, which is essential for proper engine operation. This adjustment is made by removing the clevis pin and hairpin clip from wheel yoke, raising the wheels to the desired height, and replacing the clevis pin and hairpin clip. See Figure 9.

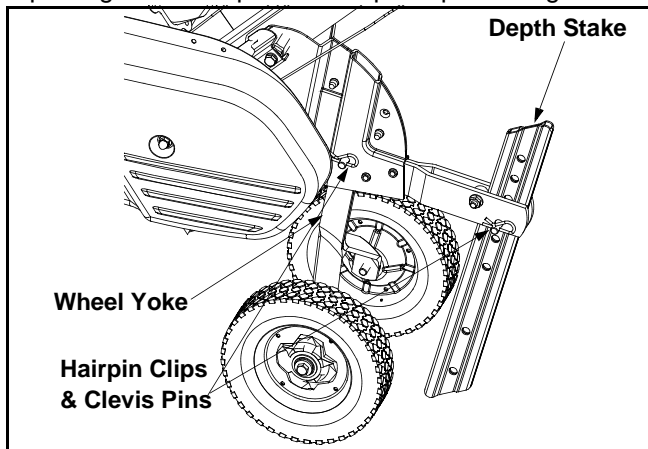

Figure 9

Removing End Caps (Model Series 390 only)

The end cap, which are used to avoid tilled soil from overflowing onto unwanted areas, are removable from the outer axle. Remove the hairpin clip and clevis pin that is securing each end cap and slide end cap off the axle. See Figure 10.

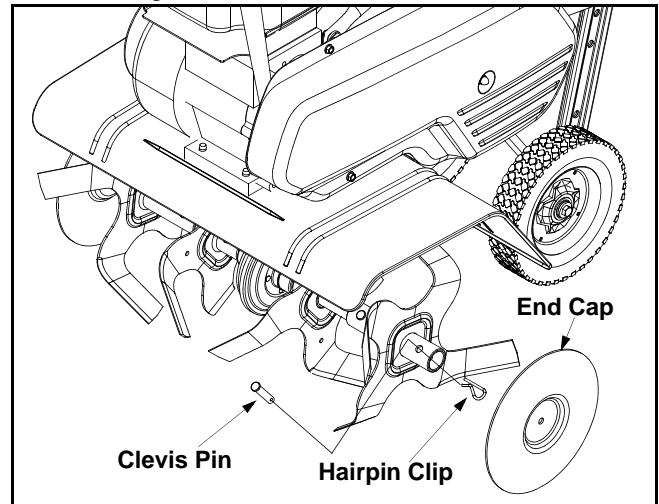

Figure 10

Controlling Speed And Tilling Depth

Wheel Yoke Adjustment

Place wheel yoke so that the wheels are forward (nearest point between wheels and tines) for shallow tilling, cultivating and transport. The forward speed will increase. Turn yoke around (farthest point between wheels and tines) for deep tilling. Forward speed will decrease. See Figure 11.

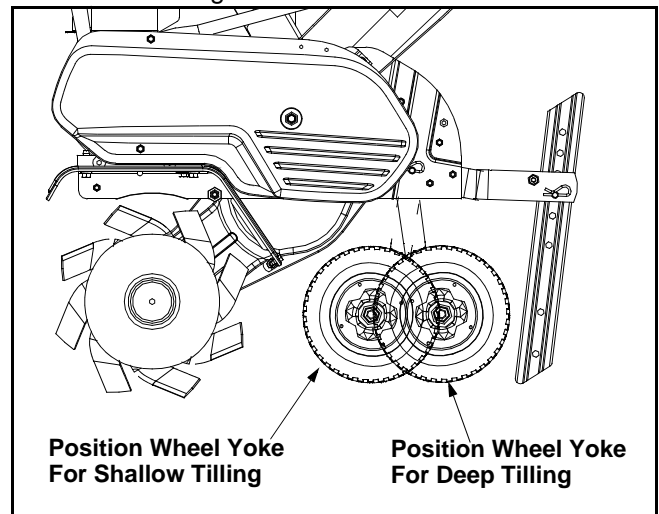

Figure 11

Depth Stake Adjustment

The depth stake acts as a brake for the tiller and controls the depth and speed at which the machine will operate. Remove the clevis pin and hairpin clip to raise or lower depth stake. See Figure 9.

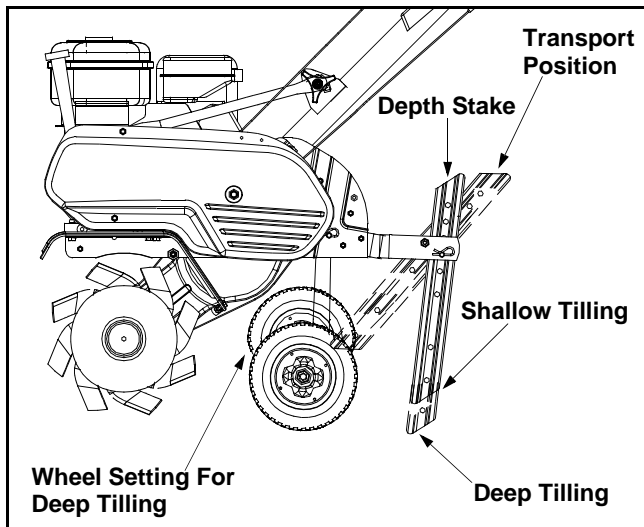

Figure 12

By increasing the depth of the depth stake, the forward speed of the machine is reduced and the working depth is increased. When the depth stake is raised, the working depth of the machine is reduced and the forward speed is increased. The working depth of the machine may be predetermined by setting the depth stake and wheels so that the wheels are about four inches from the ground when the tines and depth stake are resting on the ground. This setting will permit a working depth of about four inches. When presetting the working depth, the handles should be adjusted so the hand grips are a little above waist. The tiller will be lower when the tines and depth stake penetrate the ground. See Figure 12.

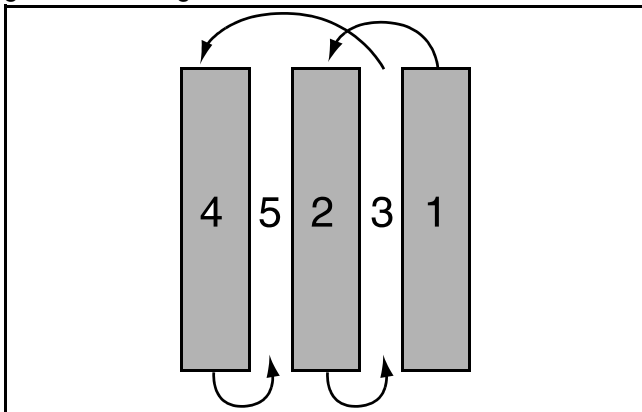

Figure 13

When tilling, leave approximately 8 inches of untilled soil between the first and second tilling paths, then make the third path between the first and second. In some soils, the desired depth is obtained the first time over the garden. In other soils, the desired depth is obtained by going over the garden two or three times. In the latter case, the depth stake should be lowered before each succeeding pass over the garden. Passes should be made across the length and width of the garden alternately. Rocks which are turned up should be removed from the garden area. See Figure 13.

Handle Pressure

Further control of tilling depth and travel speed can be obtained by variation of pressure on the handles.

- A downward pressure on the handles will reduce the working depth and increase the forward speed.
- An upward pressure on the handles will increase the working depth and reduce the forward speed.

The type of soil and working conditions will determine the actual setting of the depth stake and the handle pressure required.

Throttle Control

The throttle control lever adjusts the engine speed and stops the engine. With the throttle control lever pushed completely forward, the carburetor is in START position. Pulling the throttle control back slightly adjusts the engine speed to FAST. Pulling the throttle back further reduces the engine speed to SLOW. Pull the throttle completely back to stop the engine.

Use maximum engine speed for deep tilling. Move the throttle control to SLOW when transporting the tiller.

Transporting The Tiller

To transport the tiller to or from the garden, pivot the depth stake forward, out of the way. See Figure 12. With the throttle control in SLOW position, the unit will walk freely on top of the lawn. If the operator does not allow the tiller to move freely, the unit will start to till the surface.

Cultivating

For cultivating, a two to three inch depth is desirable. Setting the wheels and depth stake so that the wheels are about two inches above the ground while the tiller is resting on the tines and depth stake will allow the machine to work at cultivating depth. The throttle should be set to control forward movement to a slow walking speed. With the outer tines installed, the working width of the machine is 22 or 24 inches. For cultivation, this may be reduced to 13 inches by removing the outer tines. Refer to the Adjustment Section. When laying out plant rows, be sure to allow enough width to permit cultivation between the rows. In growing corn or similar crops, check-row planting will permit cross cultivation and practically eliminate hand hoeing. See Figure 14.

The tiller has many uses other than tilling and cultivating a garden. One of these is the preparation of lawn area for seeding. The tiller will prepare a deep seed bed which will be free of hard untilled spots, allowing a better stand of grass to grow. The tiller is very useful for loosening hard soil for excavation with a shovel. No tedious handwork will be necessary. Your tiller may be used for mixing compost in the pile, or for mixing it with the soil in your garden. This should be done after the soil has been broken to the full working depth. The compost should be worked in to a depth of six to seven inches. This may be done by working the length of the garden and then by making separate passes across its width. The addition of decayed

organic matter will substantially increase the fertility of your garden. For proper decaying action, fertilizer should be applied and worked in with the mulch materials. Breaking up leaves and straw and mixing it with several inches of soil causes the soil to hold moisture longer and allows proper aeration of the plant root system. This also retards the growth of weeds.

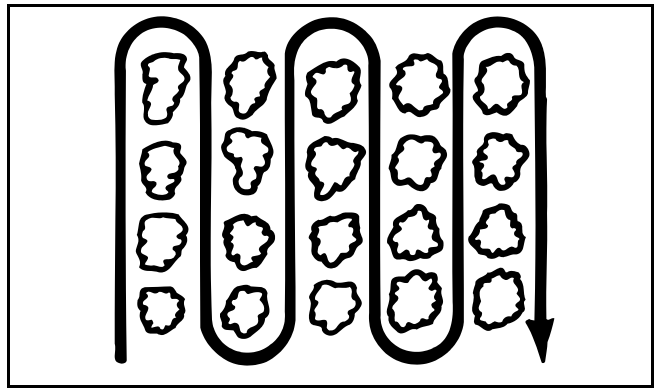

Figure 14

SECTION 5: MAKING ADJUSTMENTS



WARNING: Disconnect the spark plug wire and ground it against the engine before performing any adjustments.

Engine Adjustment

Refer to the separate engine manual for engine adjustment instructions.

Wheel Adjustments

To adjust the wheel yoke and wheel position, refer to the Operating Section.

Clutch Control Adjustments

To adjust the clutch controls, refer to the Final Adjustment section of assembly instructions.

Depth Stake Adjustment

To adjust the depth stake, refer to the Operating Section.

Tine Width Adjustment

The tilling width of the unit is 22 inches. Tilling width can be increased to 24 inches by removing the clevis pins and hairpin clips, sliding the outer tines out one inch, and securing in this position with the clevis pins and hairpin clips. For cultivation, reduce the tine width to 13 inches by removing the outer tines completely. See Figure 15.

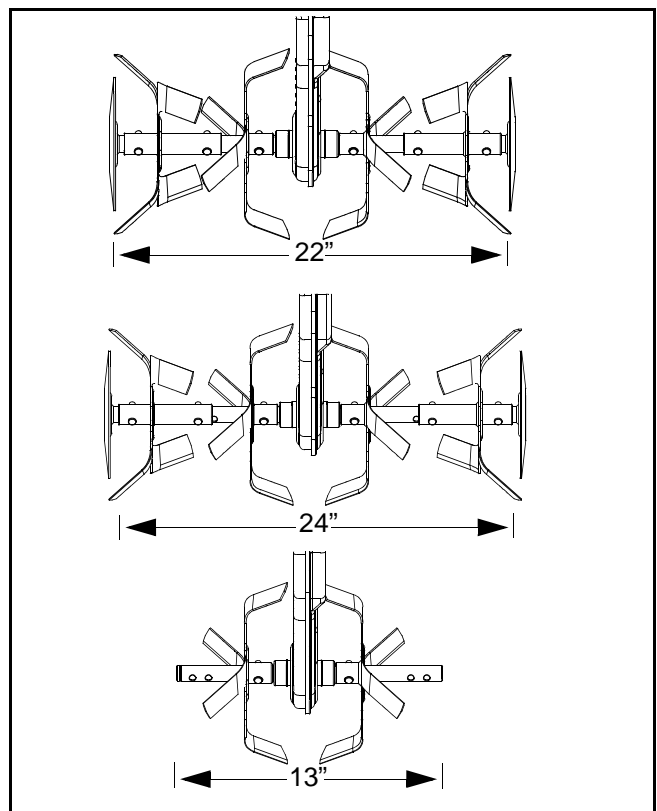

Figure 15

SECTION 6: MAINTAINING YOUR TILLER



WARNING: Disconnect the spark plug wire and ground it against the engine before performing any repairs or maintenance.

Engine

Refer to the separate engine manual for engine maintenance instructions.

Maintain **engine oil** as instructed in the separate engine manual packed with your unit. Read and follow instructions carefully.

Service **air cleaner** every ten hours under normal conditions. Clean every hour under extremely dusty conditions. Poor engine performance and flooding usually indicates that the air cleaner should be serviced. To service the air cleaner, refer to the separate engine manual packed with your unit.

IMPORTANT: Never run your engine without air cleaner completely assembled.

The **spark plug** should be cleaned and the gap reset every 25 hours of engine operation. Spark plug replacement is recommended at the start of each tiller season; check engine manual for correct plug type and gap specification.

Clean the engine regularly with a cloth or brush. Keep the cooling system (blower housing area) clean to permit proper air circulation which is essential to engine performance and life. Be certain to remove all dirt and combustible debris from muffler area.

Lubrication

Pivot Points

Remove the belt cover and lubricate all moving parts and pivot points at least once a season using SAE 30 engine oil.

Chain Drive

The chain case is pre-lubricated and sealed at the factory.

Cleaning Tine Area

Clean the underside of the tine shield after each use. The dirt washes off the tines easier if rinsed off immediately instead of after it dries. Always towel dry the tiller afterwards and apply a light coat of oil or silicone to prevent rusting or water damage.

IMPORTANT: Never use a "pressure washer" to clean your tiller. Water can penetrate tight areas of the tiller and its chain case and cause serious damage to the unit.

Belt Replacement

Your tiller has been engineered with belts made of special material (Kevlar Tensile). They should not be replaced with an off-the-shelf belt. If belt replacement is required, order belt or belts by part number from your nearest authorized service dealer. See parts list.

Reverse Drive Belt (Model Series 390 Only)

- Disconnect and ground the spark plug wire against the engine. Remove the belt cover from the left side of the tiller as follows.
- Remove two self-tapping screws and flat washers from the front of belt cover. See Figure 16.

- Remove the hex stop nut and flat washer from the side of the belt cover. Remove belt cover.

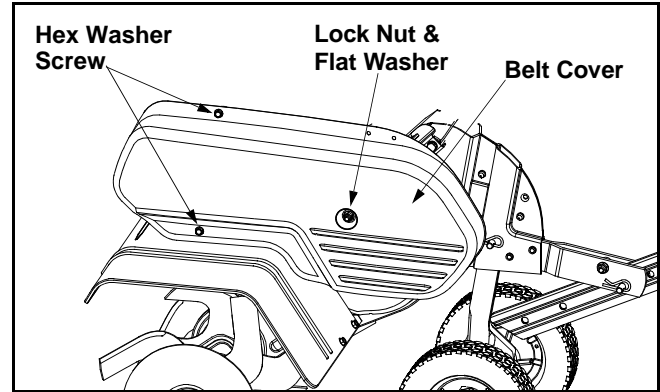

Figure 16

- Lift the belt off the transmission pulley.
- Remove the hex nut which secures the reverse idler pulley to the idler bracket. Slide idler pulley out and remove the belt. See Figure 17.

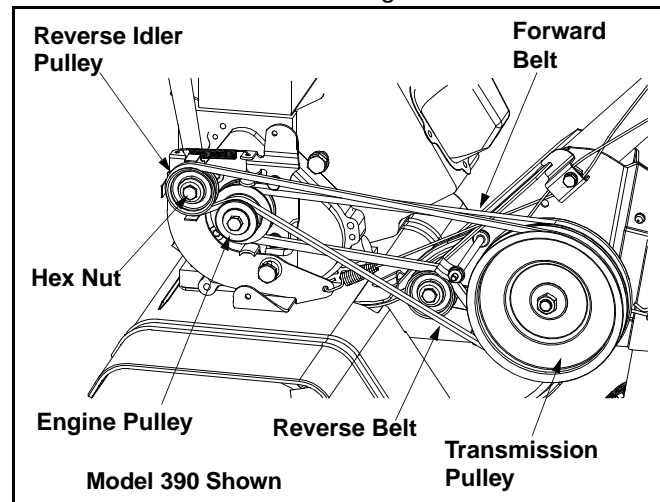

Figure 17

- Reassemble the new belt, following instructions in reverse order. Make certain the reverse drive belt is assembled with the wide side of the belt against the transmission and engine pulleys. Be certain to adjust the clutch control as instructed in the final clutch adjustment section of assembly instructions.

Forward Drive Belt

- **Model Series 340 thru 345:** Remove the belt cover by following steps 1 thru 3 of the previous section.
- **Model Series 390:** Remove the reverse drive belt as instructed in the previous section.
- Remove the belt keeper from the idler pulley by removing the idler pulley nut.
- Lift belt off the idler pulley and transmission pulley. See Figure 18.
- Using a 9/16" wrench, remove bolt from engine pulley.
- Push reverse idler pulley bracket forward, and remove engine pulley and belt. See Figure 18.

- Reassemble the new belt, following instructions in reverse order. Make certain the forward drive belt is assembled with the wide side of the belt away from the transmission and engine pulleys.

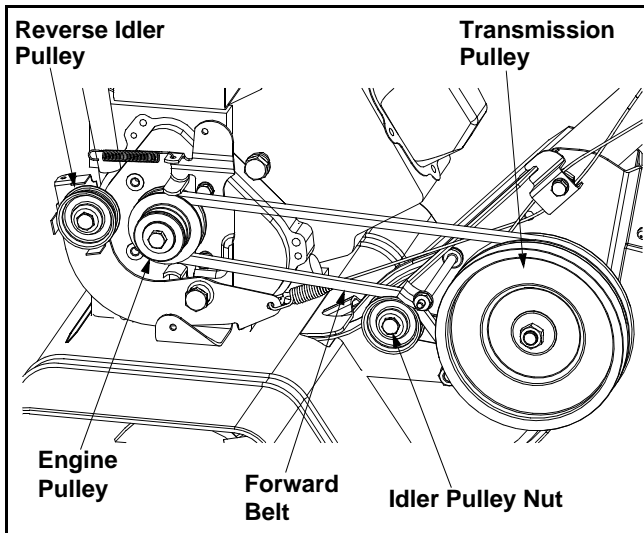

Figure 18

- Be certain to adjust the clutch control as instructed in the final clutch adjustment section of assembly instructions.

Off-Season Storage

If the tiller will not be used for a period longer than 30 days, the following steps should be taken to prepare the tiller for storage.

- Clean the exterior of engine and the entire tiller thoroughly. Lubricate the tiller as described in the lubrication instructions.
- We do not recommend the use of pressure washers to clean your unit. They may cause damage to pulleys, bearings, or the engine. The use of pressure washers will result in shortened life and reduce serviceability.
- Refer to the engine manual for correct engine storage instructions.
- Wipe tines with oiled rag to prevent rust.
- Store tiller in a clean, dry area. Do not store next to corrosive materials, such as fertilizer.

NOTE: *When storing any type of power equipment in an unventilated or metal storage shed, care should be taken to rustproof the equipment. Using a light oil or silicone, coat the equipment and especially any springs, bearings, and cables.*

SECTION 7: TROUBLE SHOOTING GUIDE

Trouble	Possible Cause(s)	Corrective Action
Engine fails to start	Fuel tank empty, or stale fuel. Throttle control lever not in correct starting position (if equipped). Blocked fuel line. Dirty aircleaner. Choke not in ON position (if equipped). Spark plug wire disconnected. Faulty spark plug. Engine flooded.	Fill tank with clean, fresh gasoline. Fuel will not last over thirty days unless a fuel stabilizer is used. Move throttle lever to start position. Clean fuel line. Refer to the engine manual packed with your unit. Move switch to ON position. Connect wire to spark plug. Clean, adjust gap or replace. Refer to the engine manual packed with your unit.
Engine runs erratic	Unit running on CHOKE (if equipped). Spark plug wire loose. Blocked fuel line or stale fuel. Vent in gas cap plugged. Water or dirt in fuel system. Dirty air cleaner. Carburetor out of adjustment.	Move choke lever to OFF position. Connect and tighten spark plug wire. Clean fuel line; fill tank with clean, fresh gasoline. Fuel will not last over thirty days unless a fuel stabilizer is used. Clear vent. Drain fuel tank. Refill with fresh fuel. Refer to the engine manual packed with your unit. Refer to the engine manual packed with your unit.
Engine overheats	Engine oil level low. Dirty air cleaner. Air flow restricted. Carburetor not adjusted properly.	Fill crankcase with proper oil. Refer to the engine manual packed with your unit. Refer to the engine manual packed with your unit. Adjust carburetor as instructed in separate engine manual.
Tines do not engage	Foreign object lodged in tines. Tine clevis pin(s) missing. Pulley and idler not in correct adjustment. Control cable not adjusted properly. Belt worn and/or stretched.	Dislodge foreign object. Replace tine clevis pin(s). Take unit to authorized service dealer. Adjust control cable (see assembly instructions). Replace belt.

NOTES

SECTION 8: ILLUSTRATED PARTS LIST

Model Series 340 Thru 345

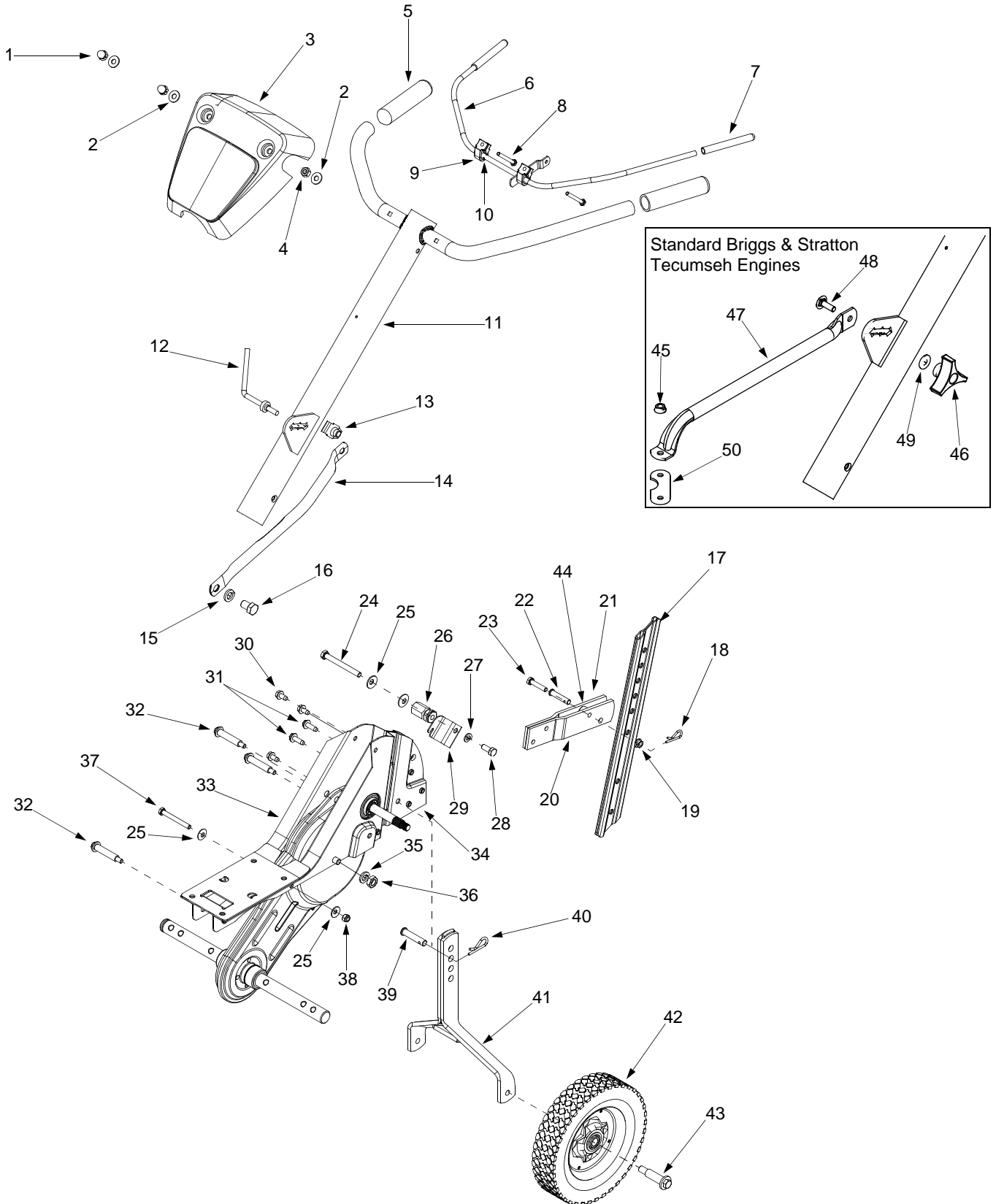

Model Series 340 Thru 345

Ref. No.	Part No.	Part Description	Ref. No.	Part No.	Part Description
1.	712-0442	Acorn Lock Nut 1/4-20	26.	711-1036	Spec. Hex Nut
2.	736-3020	Flat Washer.271" I.D. x.630" O.D.	27.	736-0119	L-Wash. 5/16" I.D.
3.	731-1599	Handle Cover	28.	710-3008	Hex Bolt 5/16-18 Gr. 5
4.	712-0287	Hex Nut 1/4-20 Gr.2	29.	786-0129	Cable Guide Bracket
5.	720-0274	Handle Grip	30.	710-0604	Hex Wash Screw 5/16-18 x.62"
6.	686-0083	Clutch Handle Assembly	31.	710-0602	Hex Wash. Hd. TT-Tap Scr.
7.	720-0269	Clutch Grip	32.	738-0934	Shdl. Bolt 5/16-18
8.	710-0641	Hex Bolt 1/4-20 x 2.25" Lg. Gr.5	33.	786-0138A	Frame (R.H.)
9.	731-1645A	Clutch Handle Holder	34.	786-0139A	Frame (L.H.)
10.	736-0140	Flat Washer.385" I.D. x.62" O.D.	35.	736-0171	Lock Washer 7/16
11.	649-0039	Handle Assembly Comp. †	36.	712-0240	Jam Nut 7/16-20 Gr. 2
	649-0022B	Handle Assembly Comp. ††	37.	710-0176	Hex Bolt 5/16-18 x 2.75" Lg.
12.	647-0042	Adjustment Crank †	38.	712-0429	Hex Nyloc Nut 5/16-18 Thd.
13.	726-0211	U Nut 5/16-18 †	39.	711-0415	Clevis Pin
14.	749-1101	Handle Brace †	40.	714-0149B	Cotter Pin
15.	736-0921	Lock Washer 1/2 †	41.	686-0081A	Wheel Hanger Brkt. Assy
16.	710-3194	Hex Bolt 1/2-20 Gr. †	42.	734-1566	Wheel Ass'y 8" x 1.75"
17.	786-0005	Depth Bar	43.	738-0929	Shoulder Screw.496 x 1.445
18.	714-0149B	Cotter Pin	44.	750-0890	Spacer
19.	712-3004A	Hex Flange L-Nut 5/16-18	45.	712-3004A	Hex Flange L-Nut 5/16-18 Thd. ††
20.	786-0003	Tail Piece Bracket (L.H.)	46.	720-0195	Hand Knob ††
21.	786-0004	Tail Piece Bracket (R.H.)	47.	749-0915A	Engine Tube Brace (Std. B&S)
22.	711-0415	Clevis Pin		749-1082	Engine Tube Brace (Tec.)
23.	710-0805	Hex Bolt 5/16-18 x 1.5" Lg.	48.	710-1236	Carr. Bolt 5/16-18 x 1 ††
24.	710-0189	Hex Bolt 5/16-18 x 3" Lg.	49.	736-0242	Bell. Wash.34" I.D. ††
25.	736-0242	Wash. Bell.340" I.D. x.872" O.D.	50.	786-0159	Engine Brkt. (Std B&S)

† Briggs & Stratton Intek Engine

†† Standard Briggs & Stratton and Tec. Engine

Model Series 340 Thru 345

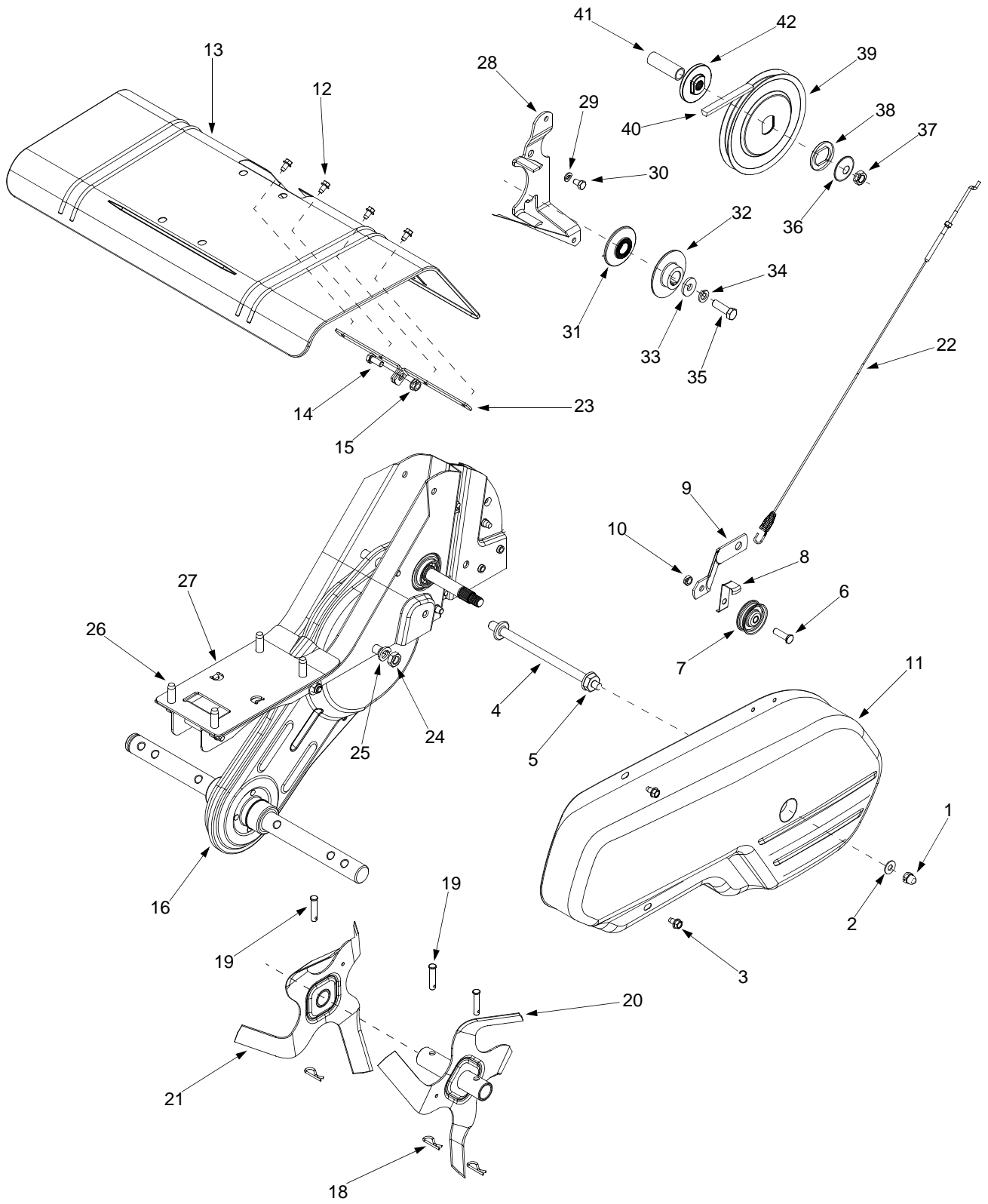

Model Series 340 Thru 345

Ref. No.	Part No.	Part Description	Ref. No.	Part No.	Part Description
1.	712-0392	Hex L-Stop nut 1/4-28	22.	746-0918	Forward Clutch Cable
2.	736-3020	Flat Wash.266" I.D. X.625" O.D.	23.	786-0053	Tine Shield Bracket
3.	710-0599	Hex Washer Screw 1/4-20 x.5"	24.	736-0171	L-Wash. 7/16" I.D.
4.	711-0920	Belt Cover Bolt	25.	712-0240	Hex Nut 7/16-20 Thd.
5.	712-3004A	Hex Flange Top L-Nut 5/16-18	26.	710-0502A	Hex Washer Screw 3/8-16 x 1.25"
6.	710-0723	Hex Hd. Scr. 3/8-16 x 1.25" Lg.	27.	786-0145A	Engine Plate
7.	756-0313	FI-Idler 2.12" O.D.	28.	786-0039B	Bracket Cover
8.	786-0149	Idler Belt Keeper	29.	736-0119	Lock Washer 5/16
9.	786-0144	Idler Bracket	30.	710-0107	Hex Bolt 5/16-24 x.5"
10.	712-0266	Hex Cent. Jam Nut 3/8-16 Thd.	31.	756-0971	Inner Engine Pulley Half
11.	786-0056	Belt Cover	32.	756-0972	Outer Engine Pulley Half
12.	710-0599	Hex Washer Screw 1/4-20 x.5"	33.	736-0258	Flat Washer.385 ID x 1.0 OD
13.	786-0035A	Tine Shield	34.	736-0169	Lock Washer 3/8
14.	710-3008	Hex Hd. Cap Scr. 5/16-18 x.75" Lg	35.	710-0191	Hex Bolt 3/8-24 x 1.25"
15.	712-3004A	Hex Flange Top L-Nut 5/16-18	36.	736-0112	Bell-Wash.525" I.D. x 1.5" O.D.
16.	686-0091	Chain Case Assembly Complete	37.	712-3029	Hex Jam Nut 1/2-20 Thd. (Gr. 5)
18.	714-0149B	Internal Cotter Pin	38.	736-0312	Retainer Washer Bearing
19.	711-0415	Clevis Pin	39.	756-0585	FI-Pulley 6" Dia.
20.	642-0005	Outer Tine Assembly L.H.	40.	754-0428	V-Belt (Forward)
	642-0004	Outer Tine Assembly R.H.	41.	750-0892	Spacer.64" Dia. x 2.4" Lg.
21.	642-0003	Inner Tine Assembly L.H.	42.	748-0350	Pulley Mounting Adapter
	642-0002	Inner Tine Assembly R.H.			

Model Series 390

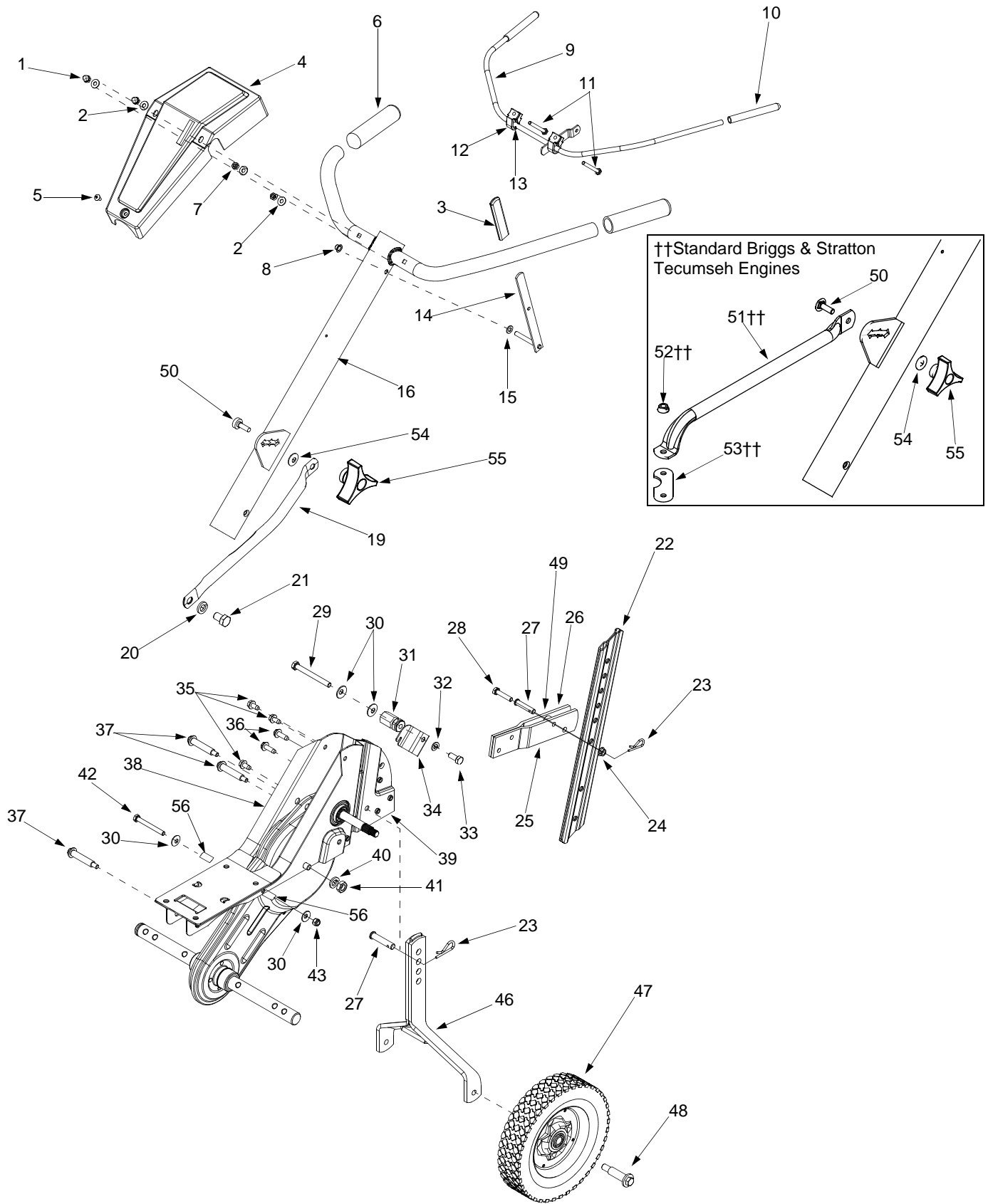

Model Series 390

REF. NO.	PART NO.	DESCRIPTION	REF. NO.	PART NO.	DESCRIPTION
1.	712-0442	Acorn Lock Nut 1/4-20	30.	736-0242	Wash. Bell.340" I.D. x.872" O.D.
2.	736-3020	Flat Washer.271" I.D. x.630" O.D.	31.	711-1036A	Spec. Hex Nut
3.	720-0270A	Reverse Handle Grip	32.	736-0119	L-Wash. 5/16" I.D.
4.	731-1600	Handle Cover w/o throttle	33.	710-3008	Hex Bolt 5/16-18 Gr. 5
5.	710-0779A	Truss Mach. Scr. #10 x 1/2" Lg.	34.	786-0129	Cable Guide Bracket
6.	720-0274	Handle Grip	35.	710-0604A	Hex Washer Screw 5/16-18 x.62" Lg.
7.	712-0287	Hex Nut 1/4-20 Gr.2	36.	710-0602	Hex Wash. Hd. TT-Tap Scr.
8.	726-0135	Cap Speed Nut	37.	738-0934	Shdl. Bolt 5/16-18
9.	686-0083	Clutch Handle Assembly	38.	786-0138A	Frame (R.H.)
10.	720-0269	Clutch Grip	39.	786-0139A	Frame (L.H.)
11.	710-0641	Hex Bolt 1/4-20 x 2.25" Lg. Gr.5	40.	736-0171	Lock Washer 7/16
12.	731-1645A	Clutch Handle Holder	41.	712-0240	Jam Nut 7/16-20 Gr. 2
13.	736-0140	Flat Washer.385" I.D. x.62" O.D.	42.	710-0176	Hex Bolt 5/16-18 x 2.75" Lg.
14.	686-0014A	Reverse Handle Ass'y	43.	712-0429	Hex Nylon Nut 5/16-18 Thd.
15.	736-0264	Flat Washer.344" I.D. x.62" O.D.	46.	686-0081A	Wheel Hanger Bracket Assembly
16.	649-0022B	Handle Assembly Comp.	47.	734-1781	Wheel Ass'y 8" x 1.75"(Plastic)
19.	749-1401	Handle Brace † or †††		734-1566	Wheel Ass'y 8" x 1.75" (Steel)
20.	736-0921	Lock Washer 1/2 † or †††	48.	738-0929	Shoulder Screw.496 I.D. x 1.445 O.D.
21.	710-3194	Hex Bolt 1/2-20 Gr. 5 † or †††	49.	750-0890	Spacer
22.	786-0005	Depth Bar	50.	710-1236	Carr. Bolt 5/16-18 x 1
23.	714-0149B	Cotter Pin	51.	749-0915A	Engine Tube Brace (Std. B&S)
24.	712-3004A	Hex Flange L-Nut 5/16-18 Thd. Gr.5		749-1082	Engine Tube Brace (Tec.)
25.	786-0003	Tail Piece Bracket (L.H.)	52.	712-3004A	Hex Flange L-Nut 5/16-18 Thd. ††
26.	786-0004	Tail Piece Bracket (R.H.)	53.	786-0159	Engine Brkt. (Std. B&S)
27.	711-0415	Clevis Pin	54.	736-0242	Bell. Wash.34" I.D.
28.	710-0805	Hex Bolt 5/16-18 x 1.5" Lg.	55.	720-0195	Hand Knob
29.	710-0189	Hex Bolt 5/16-18 x 3" Lg.	56.	750-0470	Spacer

† Briggs & Stratton Intek Engine

†† Standard Briggs & Stratton and Tec. Engine

††† Honda Engine

Model Series 390

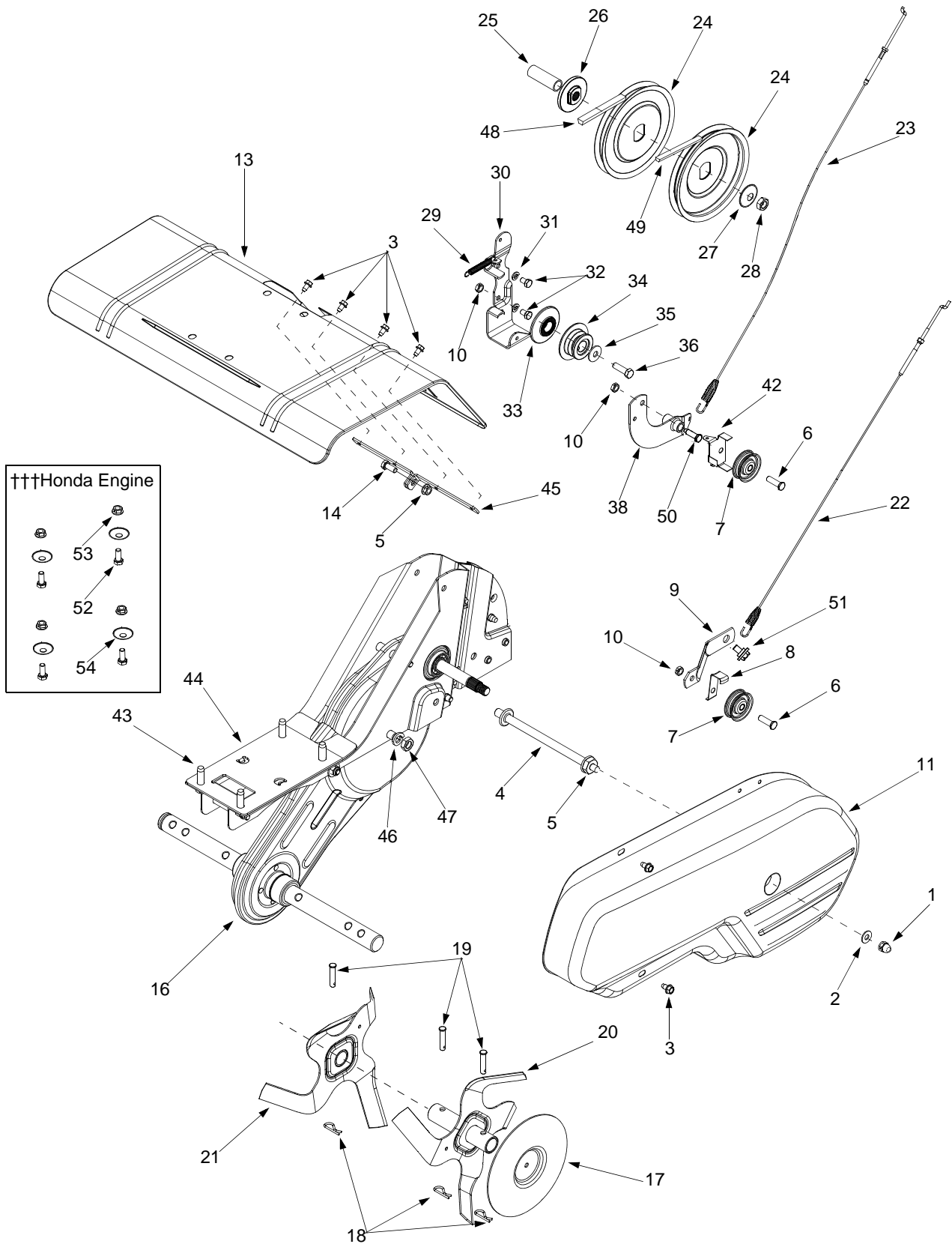

††Honda Engine

- 53
- 52
- 54

Model Series 390

REF. NO.	PART NO.	DESCRIPTION	REF. NO.	PART NO.	DESCRIPTION
1.	712-0392	Hex L-Stop nut 1/4-28	26.	748-0350	Pulley Mounting Adapter
2.	736-3020	Flat Wash.266" I.D. x.625" O.D.	27.	736-0112	Bell-Wash.525" I.D. x 1.5" O.D.
3.	710-0599	Hex Washer TT-Tap Scr. 1/4-20 x.5"	28.	712-3029	Hex Jam Nut 1/2-20 Thd. (Gr. 5)
4.	711-0920	Belt Cover Bolt	29.	732-0697	Return Spring
5.	712-3004A	Hex Flange Top L-Nut 5/16-18 (Gr.5)	30.	786-0040B	Reverse Bracket
6.	710-0723	Hex Hd. Scr. 3/8-16 x 1.25" Lg. (Gr.5)	31.	736-0119	Lock Washer 5/16
7.	756-0313	Flat Idler Pulley 2.12" O.D.	32.	710-0237	Hex Bolt 5/16-24 x.625"
8.	786-0149	Idler Belt Keeper	33.	756-0971	Engine Inner Half Pulley
9.	786-0144	Idler Bracket	34.	756-0600	Reverse Engine Pulley
10.	712-0266	Hex Cent. Jam Nut 3/8-16 Thd.	35.	736-0452	Bell Washer.396" I.D. x 1/14" O.D.
11.	786-0057	Belt Cover	36.	710-0152	Hex Bolt 3/8-24 x 1.00"
13.	786-0043A	Tine Shield	38.	686-0013	Reverse Arm Assembly
14.	710-3008	Hex Hd. Cap Scr. 5/16-18 x.75" Lg	42.	786-0041	Reverse Belt Keeper
16.	686-0091	Chain Case Assembly Complete	43.	710-0502A	Hex L-Wash. TT-Tap 3/8-16 x 1.25"
17.	686-0106	Outer Disc Plate Assembly	44.	786-0145A	Engine Plate
18.	714-0149B	Internal Cotter Pin	45.	786-0053	Tine Shield Bracket
19.	711-0415	Clevis Pin	46.	736-0171	L-Wash. 7/16" I.D.
20.	642-0023	Outer Tine Assembly L.H.	47.	712-0240	Hex Nut 7/16-20 Thd.
	642-0024	Outer Tine Assembly R.H.	48.	754-0428	V-Belt (Forward) 1/2 x 41.9"
21.	642-0003	Inner Tine Assembly L.H.	49.	754-0429	V-Belt (Reverse) 3/8 x 45.68"
	642-0002	Inner Tine Assembly R.H.	50.	738-0102	Shld. Screw.498 x 1.445
22.	746-0918	Forward Clutch Cable	51.	738-0930	Shld. Screw.560 x.165
23.	746-0953	Reverse Clutch Cable	52.	710-0805†††	Screw 5/16-18 x 1.50
24.	756-0585	FI-Pulley 6" Dia.	53.	712-3010†††	Hex Nut 5/16-18
25.	750-0892	Spacer.64" Dia. x 2.4" Lg.	54.	736-0242†††	Bell Washer

††† Honda Engine

MANUFACTURER'S LIMITED WARRANTY FOR:



The limited warranty set forth below is given by MTD LLC with respect to new merchandise purchased and used in the United States, its possessions and territories.

“MTD” warrants this product against defects in material and workmanship for a period of two (2) years commencing on the date of original purchase and will, at its option, repair or replace, free of charge, any part found to be defective in materials or workmanship. This limited warranty shall only apply if this product has been operated and maintained in accordance with the Operator’s Manual furnished with the product, and has not been subject to misuse, abuse, commercial use, neglect, accident, improper maintenance, alteration, vandalism, theft, fire, water, or damage because of other peril or natural disaster. Damage resulting from the installation or use of any part, accessory or attachment not approved by MTD for use with the product(s) covered by this manual will void your warranty as to any resulting damage.

Normal wear parts are warranted to be free from defects in material and workmanship for a period of thirty (30) days from the date of purchase. Normal wear parts include, but are not limited to items such as: batteries, belts, blades, blade adapters, grass bags, rider deck wheels, seats, snow thrower skid shoes, shave plates, auger spiral rubber and tires.

HOW TO OBTAIN SERVICE: Warranty service is available, WITH PROOF OF PURCHASE, through your local authorized service dealer. To locate the dealer in your area, check your Yellow Pages, or contact MTD LLC at P.O. Box 361131, Cleveland, Ohio 44136-0019, or call 1-800-800-7310 or 1-330-220-4683 or log on to our Web site at www.mtdproducts.com.

This limited warranty does **not** provide coverage in the following cases:

- a. The engine or component parts thereof. These items may carry a separate manufacturer’s warranty. Refer to applicable manufacturer’s warranty for terms and conditions.
- b. Log splitter pumps, valves, and cylinders have a separate one year warranty.
- c. Routine maintenance items such as lubricants, filters, blade sharpening, tune-ups, brake adjustments, clutch adjustments, deck adjustments, and normal deterioration of the exterior finish due to use or exposure.
- d. Service completed by someone other than an authorized service dealer.

- e. MTD does not extend any warranty for products sold or exported outside of the United States, its possessions and territories, except those sold through MTD’s authorized channels of export distribution.
- f. Replacement parts that are not genuine MTD parts.
- g. Transportation charges and service calls.

No implied warranty, including any implied warranty of merchantability of fitness for a particular purpose, applies after the applicable period of express written warranty above as to the parts as identified. No other express warranty, whether written or oral, except as mentioned above, given by any person or entity, including a dealer or retailer, with respect to any product, shall bind MTD. During the period of the warranty, the exclusive remedy is repair or replacement of the product as set forth above.

The provisions as set forth in this warranty provide the sole and exclusive remedy arising from the sale. MTD shall not be liable for incidental or consequential loss or damage including, without limitation, expenses incurred for substitute or replacement lawn care services or for rental expenses to temporarily replace a warranted product.

Some states do not allow the exclusion or limitation of incidental or consequential damages, or limitations on how long an implied warranty lasts, so the above exclusions or limitations may not apply to you.

In no event shall recovery of any kind be greater than the amount of the purchase price of the product sold. **Alteration of safety features of the product shall void this warranty.** You assume the risk and liability for loss, damage, or injury to you and your property and/or to others and their property arising out of the misuse or inability to use the product.

This limited warranty shall not extend to anyone other than the original purchaser or to the person for whom it was purchased as a gift.

HOW STATE LAW RELATES TO THIS WARRANTY: This limited warranty gives you specific legal rights, and you may also have other rights which vary from state to state.

IMPORTANT: Owner must present Original Proof of Purchase to obtain warranty coverage.

MTD LLC, P.O. BOX 361131 CLEVELAND, OHIO 44136-0019; Phone: 1-800-800-7310, 1-330-220-4683