



**READ AND UNDERSTAND ALL INSTRUCTION, WARNING, AND DANGER LABELS.
PARA INSTRUCCIONES EN ESPAÑOL, REFIÉRASE AL MANUAL DEL OPERADOR.**



1

Attach the red cable to the positive (+) battery terminal and attach the black cable to the negative (-) battery terminal with the bolts and hex nuts.

Position the red rubber boot over the positive battery terminal.

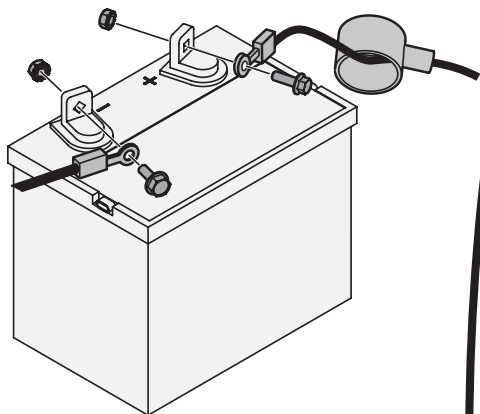

2

Remove the shipping brace from the discharge opening by grasping it between your thumb and index finger and rotating it clockwise.

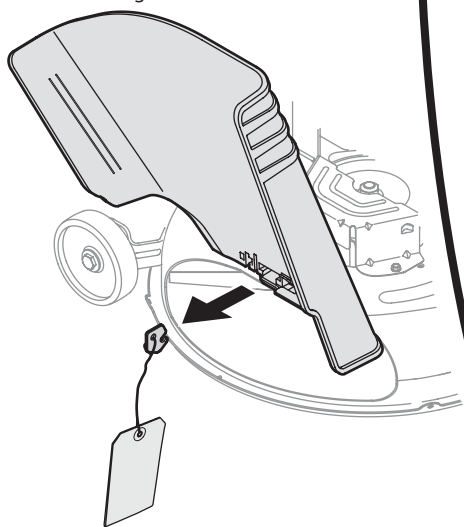

FAST START GUIDE

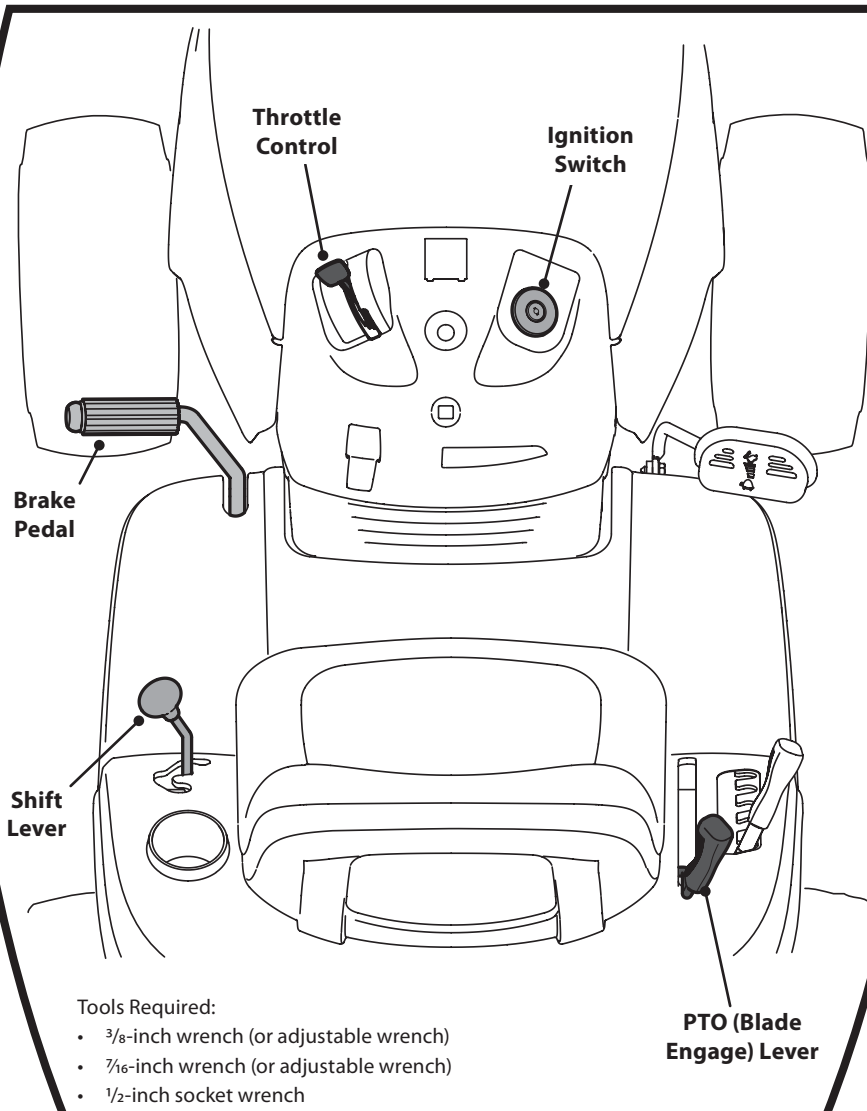

Tools Required:

- 3/8-inch wrench (or adjustable wrench)
- 7/16-inch wrench (or adjustable wrench)
- 1/2-inch socket wrench

3

1. With the wheels of the tractor pointing straight forward, place the steering wheel over the steering shaft.

2. Secure the steering wheel with the washer (cupped side down) and hex bolt.

3. Push the steering wheel cap down until it "clicks" into place.

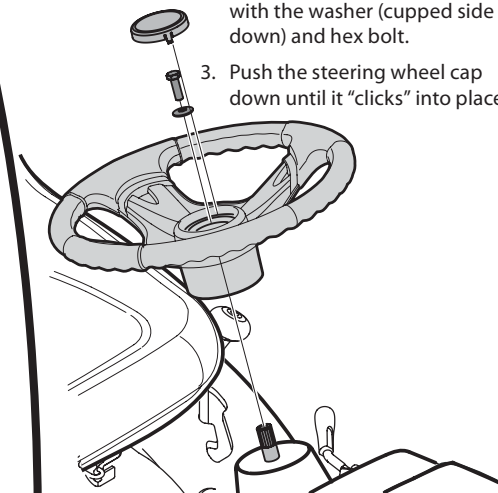

4

1. Remove the knob from the base of the seat.

2. Position the seat over the seat pan, with the two forward seat mount tabs fitting into the provided grooves.

3. Slide the seat rearward and align the center mounting hole in the seat with the slot in the seat pan and secure the seat with the knob.

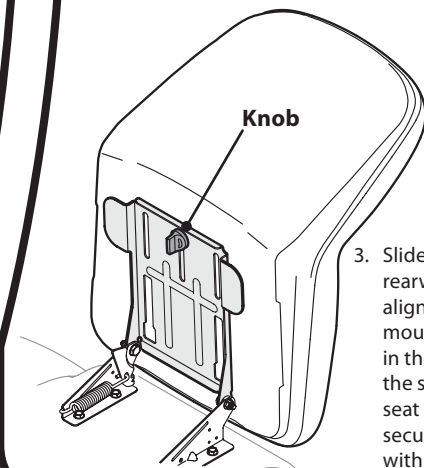

IMPORTANT: READ OPERATOR'S MANUAL AND ENGINE MANUAL THOROUGHLY AND FOLLOW THE IMPORTANT SAFE OPERATION PRACTICES BEFORE OPERATING.



Need Help? Call 1-888-TO-HELP-U



**READ AND UNDERSTAND ALL INSTRUCTION, WARNING, AND DANGER LABELS.
PARA INSTRUCCIONES EN ESPAÑOL, REFIÉRASE AL MANUAL DEL OPERADOR.**



6

Fill fuel tank with clean, fresh gasoline.
Do not fill above the base of fuel tank neck.
Place PTO (Blade Engage) Lever in Off position.

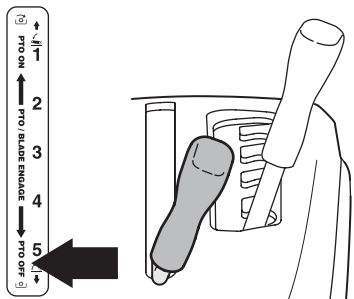

7

Place Shift Lever in N (neutral) position.

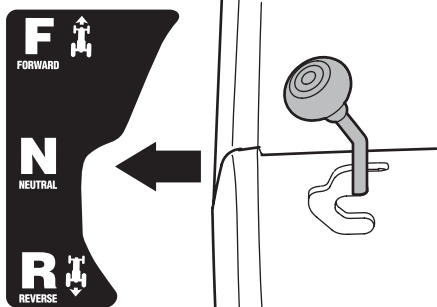

8

Fully depress the Brake Pedal.

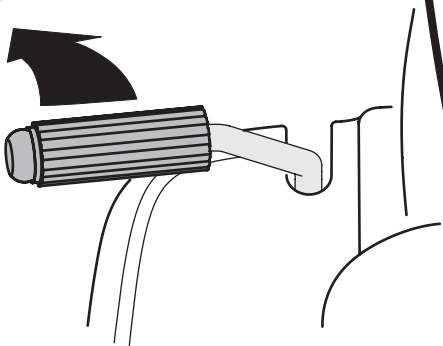

FAST START GUIDE

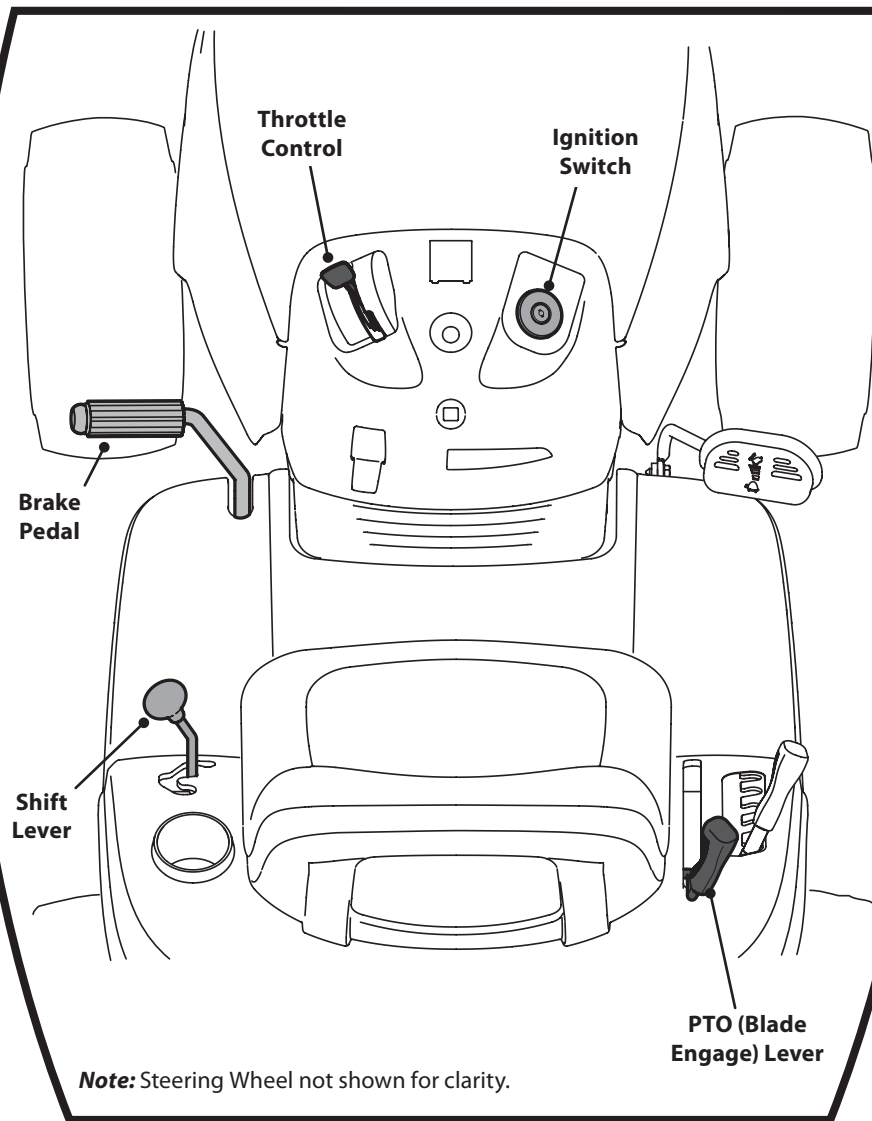

9

Move the throttle control into the Choke | position

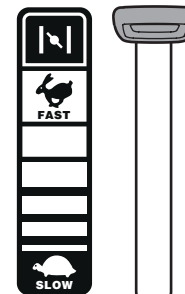

10

Insert the ignition key and turn it to the Start position.
Release the key after the engine starts.

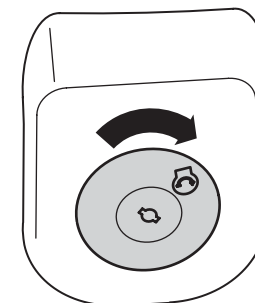

11

Move Throttle to Fast position.

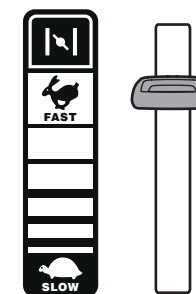

IMPORTANT: READ OPERATOR'S MANUAL AND ENGINE MANUAL THOROUGHLY AND FOLLOW THE IMPORTANT SAFE OPERATION PRACTICES BEFORE OPERATING .



Need Help? Call 1-888-TO-HELP-U