

Unpacking the Unit

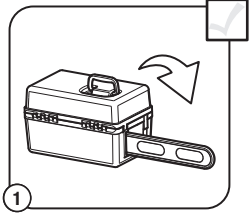

1 Remove all contents from the carrying case or carton.

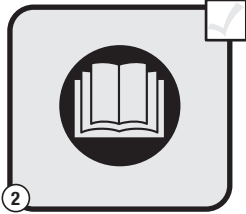

2 Read the operator's manual thoroughly before operating the unit. Follow all warnings and safety instructions. This fast guide is intended as a reference for users that have already read the operator's manual and are familiar with the necessary safety precautions.

Assembling the Unit

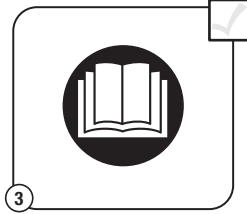

3 This unit is shipped fully assembled, but it **must be checked for proper chain tension prior to use**. Refer to the operator's manual for complete chain tensioning instructions. **Check the chain tension frequently.**

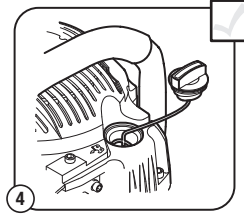

4 Set the unit on a flat, level surface. Unscrew the chain oil reservoir cap. Carefully pour fresh, clean bar and chain oil into the chain oil reservoir. **DO NOT** overfill.

Assembling the Unit

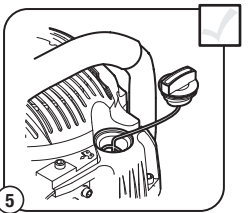

5 Reinstall the chain oil reservoir cap. Wipe up any oil that may have spilled.

NOTE: Oil will slowly flow from the reservoir onto the chain. **Check the chain oil level frequently.**

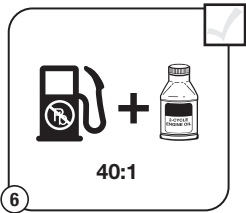

40:1

6 Mix thoroughly in a separate fuel can:
– 3.2 fl. oz. of 2-cycle engine oil
– 1 gallon of fresh unleaded gasoline (**less than 30 days old**)
NOTE: Do not mix directly in the unit fuel tank.

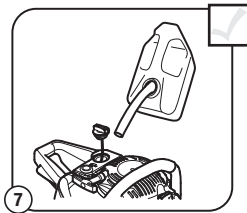

7 Place the unit on a level surface. Remove the fuel cap. Fill the fuel tank. Replace the fuel cap. Move the unit at least 30 ft. (9.1 m) from the fuel container and the fueling site before starting the engine.

Starting the Unit

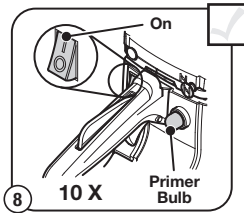

8 Move the On/Off switch to the On position.

Press the primer bulb **10 times**, or until fuel is visible.

Make sure the chain brake is disengaged. Pull the chain brake lever back toward the front handle.

Starting the Unit

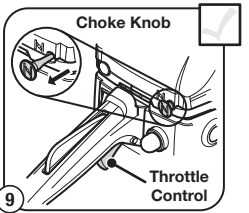

9 **DO NOT** touch the throttle control. Pull the choke knob out to **Position 1**.

Set the unit on a flat, level surface. Clear the area of any objects that could contact the saw chain.

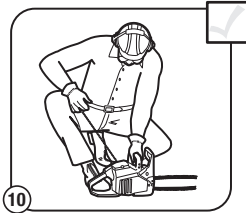

10 **DO NOT** touch the throttle control. Crouch in the starting position. Hold the front handle with the left hand. Hold the starter rope grip with the right hand. Insert the right foot into the boot loop to help hold the unit firmly in place.

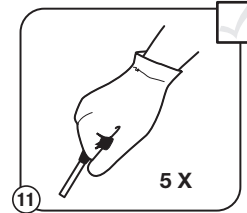

11 **DO NOT** touch the throttle control. Pull the starter rope with a controlled and steady motion **5 times**.

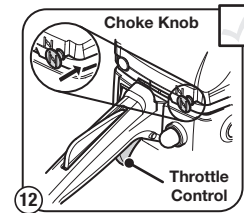

12 **DO NOT** touch the throttle control. Push the choke knob in to **Position 2**.

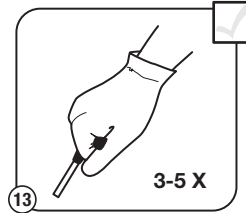

13 **DO NOT** touch the throttle control. Pull the starter rope with a controlled and steady motion **3 to 5 times** to start the engine. Allow the engine to warm up for 30 to 60 seconds.

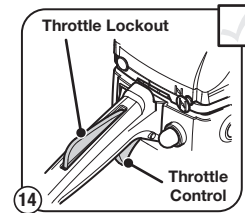

14 Press and hold the throttle lockout. Lightly squeeze and release the throttle control to idle the engine. Press the throttle lockout and squeeze the throttle control to accelerate the engine, as needed.

Test the chain brake. Refer to the operator's manual for complete instructions.

ASSEMBLY TOOLS REQUIRED:

- Multi-purpose tool (provided) - for chain tensioning

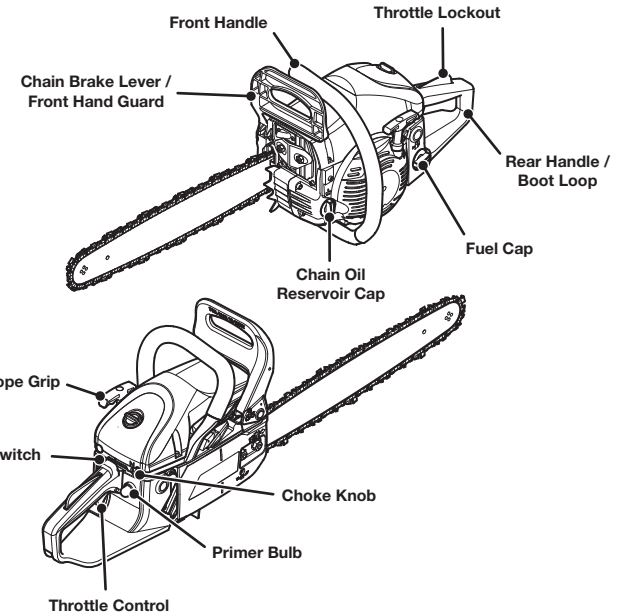

Need Help?

Call 1-866-206-2707 (U.S.)
or 1-877-696-5533 (Canada)

DIDN'T START?

Repeat the starting instructions.

If the unit still fails to start, refer to the operator's manual for additional starting and troubleshooting information.

